

# Graduate Guidelines

Department of  
Electrical and Computer Engineering



# Department of Electrical and Computer Engineering

University of Florida  
P. O. Box 116200  
Gainesville, FL 32611

Revised Fall 2006

Department Administration:

**Mark E. Law**  
Department Chair

**Robert M. Fox**  
Associate Chair

**Gijs Bosman**  
Graduate Coordinator  
565 NEB  
(352) 392-9758  
Email: [gbosm@ece.ufl.edu](mailto:gbosm@ece.ufl.edu)

For Information:

**Shannon Chillingworth**  
Student Services Office  
230 Larsen Hall  
P. O. Box 116200  
University of Florida  
Gainesville, FL 32611  
(352) 392-9758  
Email: [schill@ece.ufl.edu](mailto:schill@ece.ufl.edu)

# Table of Contents

<b>I. Graduate Faculty and Research Areas .....</b>	<b>4</b>
1. Computer Engineering .....	4
2. Devices .....	5
3. Electromagnetics and Electric Energy Systems .....	6
4. Electronics.....	7
5. Signals & Systems .....	8
<b>II. Introduction .....</b>	<b>10</b>
1. Degree Requirements .....	10
2. Articulation Requirements.....	12
<b>III. Master's Degree - Thesis Option .....</b>	<b>13</b>
1. Course Requirements .....	13
2. Appointment of Supervisory Committee .....	13
3. Submission of Master's Thesis .....	14
4. Final Examination Procedures .....	14
5. Checklist for Thesis Option .....	15
<b>IV. Master's Degree - Non-thesis Option .....</b>	<b>16</b>
1. Requirements .....	16
2. Final Examination Procedures - <i>Master of Science only</i> .....	16
3. Checklist for Non-thesis Option .....	17
<b>V. Doctor of Philosophy Degree .....</b>	<b>18</b>
1. Course Requirements and Period of Concentrated Study.....	18
2. Appointment of Supervisory Committee .....	18
3. Ph.D. Course Breadth Requirement .....	19
4. Leave of Absence Policy.....	19
5. Official Minor .....	19
6. Written Portion of the Qualifying Exam .....	19
7. Oral Portion of the Qualifying Exam.....	20
8. Final Examination and Submission of Dissertation.....	21
10. Checklist for Ph.D. Degree .....	22
<b>VI. Administrative Procedures .....</b>	<b>24</b>
1. Graduate Bulletin Boards .....	24
2. Degree Audits .....	24
3. ECEL Email Accounts .....	24
4. Graduate Registration .....	24
5. Add/Drop Policy .....	25
6. GPA and Probation Policies.....	25
7. Transfer of Credits .....	25
8. Financial Aid.....	26
9. Tuition Waivers .....	26
10. Readmission Procedures.....	26
<b>VII. Graduate Course Descriptions.....</b>	<b>28</b>
<b>VIII. Graduate Division Flow Diagrams .....</b>	<b>36</b>
<b>IX. Breadth Sequences .....</b>	<b>42</b>

# I. Graduate Faculty and Research Areas

## 1. Computer Engineering

This division focuses on the theoretical and applied research by which next generation, high-performance computing and communications systems are designed, developed, and exploited. Research fields include high-performance computer architectures and networks, parallel and distributed computing, fault-tolerant computing, real-time systems, intelligent systems microprocessor-based systems, and performance analysis.

### ***Antonio Arroyo***

PhD, University of Florida, 1981. Machine intelligence, artificial intelligence, microprocessors, microcomputers, expert systems, human-machine interaction, computer software and hardware systems, pattern recognition, digital signal / natural language and speech processing

### ***P. Oscar Boykin***

Ph.D., University of California-Los Angeles, 2002. Nanocomputing, Quantum Computing, Quantum Communication, Quantum Cryptography, Neural Coding, Peer-to-peer Networking, Large Scale Networks.

### ***Yuguang (Michael) Fang***

Ph.D., Boston University, 1997. Wireless networks and mobile communications; personal communication services (PCS).

### ***Renato Figueiredo***

PhD, Purdue University, 2001. Computer architecture, network computing, distributed systems.

### ***Jose A. B. Fortes***

BellSouth Eminent Scholar Chair; PhD, University of Southern California, 1984. Network computing, advanced computing architecture, biologically inspired nanocomputing, distributed information processing systems.

### ***Jianbo Gao***

PhD, University of California-Los Angeles, 2000. Telecommunications and networking, traffic engineering, QoS, internet dynamics, routing instability, modeling of non-Gaussian noise in wireless communications, nonlinear time series analysis using chaos and fractal theory, bioinformatics, biomedical engineering.

### ***Alan George***

PhD, Florida State University, 1991. High-performance computer networks, architectures, systems, algorithms, and services for applications in parallel, distributed, reconfigurable, and fault-tolerant computing.

### ***Herman Lam***

PhD, University of Florida, 1979. Computer engineering, database management and computer architecture.

***Haniph A. Latchman***

PhD, Oxford University, 1986. Mathematical systems theory, control systems, communication theory, data communication networks, multimedia information systems.

***Tao Li***

PhD, University of Texas at Austin, 2004. Computer and digital system architecture; interaction of computer architecture, emerging applications, operating systems, programming language features, managed run-time environments; modeling, simulation and evaluation of computer systems.

***Janise McNair***

PhD, Georgia Institute of Technology, 2000. Wireless and mobile networking, next generation wireless systems, medium access control protocols.

***Dapeng Wu***

PhD, Carnegie Mellon University, 2003. Wireless communications, video coding, multimedia communication, computer and communication networks, information and network security, pervasive and mobile computing, information and communication theory, signal processing, detection and estimation theory.

**2. Devices**

The device division focuses on the behavior, fabrication, and design of devices. These include optoelectronics (lasers, solar cells, detectors), transistors (SiGe, MIS, III-V), MEM's (mechanical, optical, biological sensors), and nanodevice concepts (CNT, Molecular, Silicon-based). There is research on both how materials interact with voltage, current, photons, and radiation as well as the current-voltage relationship of device structures.

***David P. Arnold***

PhD, Georgia Institute of Technology, 2004. Design, fabrication, and characterization of magnetic and electromechanical microsensors/microactuators, as well as miniaturized power and energy systems

***Gijs Bosman***

Graduate Coordinator, Ph.D., State University of Utrecht (Netherlands), 1981. Electronic noise research, quantum devices.

***Jerry G. Fossum***

PhD, University of Arizona, 1971. Semiconductor device theory, modeling, and simulation; nanoelectronics, integrated circuits (ICs), IC technology computer-aided design (TCAD); silicon-on-insulator (SOI) and double-gate (DG) CMOS lcs.

***Jing Guo***

PhD, Purdue University, 2004. Modeling and simulation of nanoelectronic devices, carbon nanotube electronics and photonics, physics of nanotransistors, computational nanobiotechnology.

***Mark E. Law***

Chair, PhD, Stanford University, 1988. Design and modeling of IC fabrication process, computer modeling of semiconductor process and device behavior, numerical solution of partial differential equations.

***Arnost Neugroschel***

PhD, Technion, Israel Institute of Technology, 1973. Semiconductor device physics, device technology and characterization.

***Toshikazu Nishida***

PhD, University of Illinois-Urbana, 1988. Semiconductor sensors and devices

***Chih-Tang Sah***

PhD, Stanford University, 1956. Semiconductor electronics, semiconductor device reliability, solid state physics.

***Scott Thompson***

PhD, University of Florida, 1992. Solid state electronics and nano technology, new materials and devices to extend Moore's law, Electrical measurements and modeling of strained Si, Ge, GaN semiconductors.

***Ant Ural***

PhD, Stanford University, 2001. Carbon nanotubes, semiconductor nanowires, and related nanostructures. Integration of nanotechnology with silicon microfabrication processes. Molecular electronics, nanoscale MEMS, and nanobiotechnology.

***Huikai Xie***

PhD, Carnegie Mellon University, 2002. Semiconductor devices, integrated microsensors and microactuators, optical MEMS, biosensors, biomedical imaging, fiber optics, micro/nano fabrication technology, and multi-domain simulation.

***Peter Zory***

PhD, Carnegie-Mellon University, 1964. Semiconductor lasers physics and technology.

### **3. Electromagnetics and Electric Energy Systems**

This division spans a wide area of research of electromagnetic fields and their application. It includes power generation, distribution, and utilization of electrical energy. It also includes interaction wave guides, optical fiber, and photonic devices. UF is one of the few universities in the world conducting lightning research. Field research on lightning performed each summer both on the UF campus and at Camp Blanding, Florida.

***David P. Arnold***

PhD, Georgia Institute of Technology, 2004. Design, fabrication, and characterization of magnetic and electromechanical microsensors/microactuators, as well as miniaturized power and energy systems

***Jenshan Lin***

PhD, University of California-Los Angeles, 1994. Microwave/millimeter-wave electronics and wireless communication circuits, high speed electronics and broadband communication circuits.

***Vladimir A. Rakov***

PhD, Tomsk Polytechnic Institute, 1983. Lightning, atmospheric electricity, lightning protection.

***Muhammad H. Rashid***

Director of the UF/UWF Joint Program in Electrical & Computer Engineering, PhD, University of Birmingham (U.K.), 1976. Power electronics, motor drives, electronics control, computer and design simulation.

***Ramakant Srivastava***

PhD, Indiana University, 1973. Integrated optics and waveguide sensors.

***Martin A. Uman***

PhD, Princeton University, 1961. Lightning, atmospheric electricity, electromagnetics.

***Henry Zmuda***

PhD, Cornell University, 1984. RF/Microwave photonic systems, optically controlled phased array antennas, phased array signal processing, photonic high speed analog-to-digital conversion.

***Peter Zory***

PhD, Carnegie-Mellon University, 1964. Semiconductor lasers physics and technology.

**4. Electronics**

This division covers a broad range of topics from the manufacturing of integrated circuits to their applications in real world systems. Current research includes adaptive circuits, radio frequency circuits, VLSI design, microwave device and interconnect modeling, IC test, and modeling of materials, components and circuits for high-frequency power electronics.

***Rizwan Bashirullah***

PhD, North Carolina State University, 2004. Circuit design techniques for high-performance analog/digital VLSI, electronic circuit devices and technology, high-speed signaling techniques and circuits for biomedical applications.

***William R. Eisenstadt***

PhD, Stanford University, 1986. Microwave integrated circuits, IC packages, VLSI, high-frequency measurements, mixed-mode s-parameters.

***Robert M. Fox***

Associate Chair, PhD, Auburn University, 1986. Analog electronic circuit design.

***John G. Harris***

PhD, California Institute of Technology, 1991. Analog and digital signal processing, VLSI, adaptive and neural systems.

***Mark E. Law***

Chair, PhD, Stanford University, 1988. Design and modeling of IC fabrication process, computer modeling of semiconductor process and device behavior, numerical solution of partial differential equations.

***Jenshan Lin***

PhD, University of California-Los Angeles, 1994. Microwave/millimeter-wave electronics and wireless communication circuits, high speed electronics and broadband communication circuits.

**Kenneth K. O**

PhD, Massachusetts Institute of Technology, 1989. Electronic circuit devices and technology, microwave integrated circuits and technology, silicon device integrated circuits and technology for wireless communication.

**Scott Thompson**

PhD, University of Florida, 1992. Solid state electronics and nano technology, new materials and devices to extend Moore's law, Electrical measurements and modeling of strained Si, Ge, GaN semiconductors.

## **5. Signals & Systems**

Studies in this field are related to the transmission, creation, manipulation, and understanding of signals and systems. Signal processing looks to take data from a wide variety of sources (speech, audio, images, video, radar, sensor networks) and transforming it into useable pieces. Communication systems are design to transmit information while minimizing the corruptive effects of noise and interference.

**Jianbo Gao**

PhD, University of California-Los Angeles, 2000. Telecommunications and networking, traffic engineering, QoS, internet dynamics, routing instability, modeling of non-Gaussian noise in wireless communications, nonlinear time series analysis using chaos and fractal theory, bioinformatics, biomedical engineering.

**Jacob Hammer**

D. Sci., Technion, Israel Institute of Technology, 1980. Mathematical system theory, control systems.

**John G. Harris**

PhD, California Institute of Technology, 1991. Analog and digital signal processing, VLSI, adaptive and neural systems.

**Haniph A. Latchman**

PhD, Oxford University, 1986. Mathematical systems theory, control systems, communication theory, data communication networks, multimedia information systems.

**Jian Li**

PhD, Ohio State University, 1991. Signal processing for wireless communications and radar.

**Jose C. Principe**

PhD, University of Florida, 1979. Adaptive non-Gaussian signal processing, nonlinear dynamical systems, information-theoretic learning, applications to pattern recognition and DSP systems, information technology in education.

**John M. Shea**

Ph.D., Clemson University, 1998. Wireless communications, adaptive modulation and coding, multicast signaling, multimedia transmission over wireless channels, channel-quality estimation, spread spectrum communications.

**K. Clint Slatton**

PhD, University of Texas-Austin, 2001. Remote sensing, multiscale estimation, data fusion, statistical signal processing, lidar and radar applications.



***Fred J. Taylor***

PhD, University of Colorado, 1969. Digital signal processing, digital computer design and architecture.

***Tan F. Wong***

Ph.D., Purdue University, 1997. Wireless communications, spread spectrum systems, multiuser communications, adaptive signal processing.

***Dapeng Wu***

PhD, Carnegie Mellon University, 2003. Wireless communications, video coding, multimedia communication, computer and communication networks, information and network security, pervasive and mobile computing, information and communication theory, signal processing, detection and estimation theory.

***Liuqing Yang***

Ph.D., University of Minnesota, 2004. Ultra-Wideband (UWB) wireless communications, networking, and signal processing.

## II. Introduction

The graduate program of the Department of Electrical and Computer Engineering at the University of Florida offers the Master of Engineering (M.E.), Master of Science (M.S.), Engineer, and Doctor of Philosophy (Ph.D.) degrees. The Graduate Guidelines detail the policies and regulations governing the Master of Engineering, Master of Science, and Doctor of Philosophy programs and should be used in conjunction with the University of Florida *Graduate Catalog*. It is the responsibility of the student to be familiar with both publications and to adhere to the stated rules and policies.

More information regarding the Engineer, Joint MS/MSM, Joint JD/MS, and other degree program options can be found on the web at <http://www.ece.ufl.edu/academics/graduate/jointdegrees/main.html>.

### 1. Degree Requirements

For the Master's degree, a minimum of 30 credit hours is required. The Ph.D. degree requires the accumulation of at least 90 credit hours beyond the bachelor's degree (excluding all credit hours from an Engineer's degree).

Master's student may transfer a maximum of 9 credits from an institution approved by UF. Doctoral students may transfer up to 30 credit hours from a Master's degree in electrical and computer engineering taken at an institution approved by UF.

The Master of Engineering (M.E.) degree is awarded only to students with a B.S. in engineering, or to students who have completed appropriate articulation courses. The Master of Science (M.S.) degree is awarded to students with an undergraduate degree in any appropriate area of science or engineering.

All work counted for a Master's degree must be completed during the seven years immediately preceding the date on which the degree is to be awarded.

To graduate from any of the above-mentioned degree programs, a 3.00 is required in the overall (UF) and EEL-cumulative grade point averages.

An off-campus student who is a candidate for an electrical engineering degree must take at least half the course work from full-time University of Florida faculty members. Students can presently meet this requirement by attending lectures on the UF campus or using lectures distributed via distance learning.

No graduate credit is allowed for electrical and computer engineering courses below the 5000 level. Graduate students may take additional undergraduate courses, but credits earned in these courses are not counted toward the minimum degree requirements. A summary of the pertinent degree requirements is shown in the following table. For detailed requirements, see the appropriate sections that follow.

<b>Requirements</b>	<b>ME (Thesis)</b>	<b>ME (Non- thesis)</b>	<b>MS (Thesis)</b>	<b>MS (Non- thesis)</b>	<b>Ph.D.</b>
Total hours	30	30	30	30	90 <sup>a</sup>
EEL courses	18 <sup>*h</sup>	21 <sup>*h</sup>	18 <sup>*h</sup>	21 <sup>*h</sup>	24 <sup>**h</sup>
Minimum EEL credits	18 <sup>*h</sup>	21 <sup>*h</sup>	18 <sup>*h</sup>	21 <sup>*h</sup>	50%
Minimum number of breadth sequences	2	2	2	2	3
Minimum number of supervisory committee members	3	1	3	1	4 <sup>b</sup>
Qualifying Exam required	no	no	no	no	yes <sup>c</sup>
Final Exam	oral <sup>e</sup>	none	oral <sup>e</sup>	written <sup>d</sup>	oral <sup>f</sup>
Time limit for completing degree	7 years	7 years	7 years	7 years	5 years <sup>g</sup>

Footnotes:

\* Excludes: EEL 5905, 6905, 6910, 6932, 6940, 6971

\*\* Excludes: EEL 5905, 6905, 6910, 6932, 6940, 6971, 7979, 7980

a May include 30 hours from Master's program

b Includes one member outside the ECE department

c Written part within the first year of entry

d Exam covers one breadth sequence

e On thesis and course work

f On dissertation

g Five years from admission to candidacy

h UF courses only

## 2. Articulation Requirements

Students entering the graduate ECE program from a non-ECE background are welcome in the department.

All students must have completed course work in at least three of the eight topic areas cited in the Ph.D. qualifying exam, which currently include:

- Digital Logic
- Signals and Systems
- Electronic Circuits
- Solid-State Devices
- Electromagnetism and Energy Systems
- Microprocessor Applications
- Computer Organization and Architecture
- Data Structures and Operating Systems

These requirements may be satisfied, with a grade of B or higher, as follows:

- Previous undergraduate course work (e.g. physics course in electromagnetics, computer science courses in data structures and operating systems);
- Enrollment in and successful completion of appropriate UF undergraduate courses; or,
- Pass the Ph.D. written qualifying exam.

Additional courses may be required to fulfill necessary background material needed to successfully complete graduate-level course requirements. Many graduate-level ECE courses have implicit undergraduate course prerequisites. Students are expected to have mastered the undergraduate skills necessary to provide appropriate foundation for graduate courses they attempt.

All articulation requirements must be satisfied within the first 12 months of beginning graduate studies.

### **III. Master's Degree - Thesis Option**

The Department of Electrical and Computer Engineering offers the thesis option for the Master of Engineering and Master of Science degrees. A student seeking a Master's degree with a thesis option is required to pass an oral final examination.

#### **1. Course Requirements**

For the thesis option of a Master's degree, the student must complete at least 30 credit hours, which include a maximum of six credit hours and a minimum of three credit hours of EEL 6971 (Research for Master's Thesis). Thesis students must be registered for three credit hours of thesis (EEL 6971) in the term of graduation (Fall and Spring, and two credits in summer). The course requirements include a minimum of 18 hours of Electrical and Computer Engineering courses, excluding EEL 5905, 6905, 6910, 6932, 6940, 6971. This course requirement can only be fulfilled by completing EEL course work at the University of Florida.

Two breadth sequences are required. A listing of the breadth sequences can be found on the last page of this manual. Students must receive a grade of "C" or higher in each breadth sequence course.

Up to 18 hours of Special Topics (EEL 5934, 6935, and 7936) may be applied toward the degree. Up to six hours each of Individual Work (EEL 5905 or 6905) may be applied toward the degree.

Students holding a graduate research assistantship may register for EEL 6910 (Supervised Research) and those holding a graduate teaching assistantship may register for EEL 6940 (Supervised Teaching) with the advisor's approval. The number of credits in EEL 6910 and 6940 is limited to five credit hours each and none of these credits can be counted toward degree requirements.

A course with a final grade of C and above cannot be repeated for credit. If a student receives a grade less than a "C" for a course, s/he may retake the course and an average of both grades will be used when compiling GPA graduation requirements.

#### **2. Appointment of Supervisory Committee**

The supervisory committee is the group of faculty members that supervises and approves the student's graduate program. The committee's function is to guide the student through his/her thesis research and to administer the final examination.

The supervisory committee should be selected as soon as possible but no later than the end of the second semester. After the committee has been determined, the student should get a Supervisory Committee Form from the ECE Student Services Office (230 Larsen) and have the professors sign the form indicating their willingness to serve on the committee. The Graduate School may deny degrees to any persons who have failed to comply with this regulation at the proper time.

The committee for the Master's degree, thesis option, must consist of at least three faculty members. The chairperson and at least one member must be a graduate faculty member in Electrical and Computer Engineering department. The chairperson is usually the student's academic advisor and should advise the student in the selection of the other committee members.

### **3. Submission of Master's Thesis**

Students must submit their thesis electronically. Students should refer to the Graduate School Editorial Office for more information regarding their thesis submission. (<http://gradschool.rgp.ufl.edu/editorial/introduction.html>)

Electronic submission requires a signed EDT Submission Approval Form, Final Exam form, and one electronic copy to the Student Services Office, 230 Larsen.

### **4. Final Examination Procedures**

Within six months prior to graduation, the supervisory committee will give the student an oral examination on the thesis, on major and minor subjects, and on matters pertaining to any specific field of study.

Each student is responsible for applying for his/her degree by the published deadlines for the semester of graduation. The Degree Application form is available from the Registrar's Office, online, or through the Student Services Office. If a student fails to apply by the specified deadline, s/he will not receive the degree that semester.

It is imperative that copies of the student's thesis be given to the supervisory committee at least one week in advance of the final examination. Graduation may be delayed for those who do not adhere to this rule. When submitting your final copies of the thesis, be sure to deliver an electronic copy to the Student Services Office. The Student Services Office will not validate the Final Exam Report until this final copy is received.

Students are also required to complete an Exit Survey during the semester they plan to graduate. Students can find more information about the Exit Survey in the Student Services Office.

## 5. Checklist for Thesis Option

✓	To Do	When
	If appropriate, transfer up to 9 credit hours from graduate courses taken previously to your UF master's program.	First semester
	Appoint supervisory committee. This committee must be appointed by the end of the second semester	Second semester
	Check with the Student Services Office to see if all graduation requirements, including appropriate course hour credit, will be satisfied.	Semester before graduation
	If you have any grades less than C (i.e. D, I, or E grades), discuss your options for meeting graduation requirements.	
	Submit degree application to the Student Services Office prior to the deadline.	Semester of graduation
	Comply with Graduate School thesis and final examination deadline dates.	
	Be registered for at least the minimum number of thesis hours (3 hours in the fall and spring semester, 2 hours in the summer)	
	Schedule the Thesis Defense with the supervisory committee. Inform the Student Services Office of plans to take the examination, and reserve a conference room. The Student Services Office will send the announcement of exam and prepare the Final Exam Report.	
	At least one week in advance of the final examination, give the supervisory committee members a copy of the thesis.	
	On the day of the examination, report to the Student Services Office to pick up the necessary forms.	
	Have the Final Examination Report form and the original signature page of the thesis signed by the supervisory committee members. Return the Final Examination Report form to the Student Services Office.	
	Submit the final thesis, as required, to the department, the College Dean, and the Graduate School.	
	Complete the Exit Survey.	

## IV. Master's Degree - Non-thesis Option

The Department of Electrical and Computer Engineering offers the non-thesis option for the Master of Engineering and Master of Science degrees. The non-thesis Master of Science student is required to pass a written final examination. No final exam is required of the students pursuing the non-thesis Master of Engineering degree.

### 1. Requirements

The requirements for the non-thesis master's degree are the same as for the thesis master's degree with the following exceptions:

1. No thesis is required and no EEL 6971 credit is allowed.
2. Master of Science non-thesis students must pass a final written examination. Master of Engineering non-thesis students do not have a written examination.
3. At least 21 hours of ECE course work must be taken. This course requirement can only be fulfilled by completing EEL course work at the University of Florida. EEL 5905, 6905, 6910, 6932, and 6940 are not counted for this 21-hour requirement.
4. Requires 30 credits of letter-graded courses. S/U grades will not be counted toward degree requirements.
5. Complete at least two of the ECE breadth sequences. Students must receive a grade of "C" or higher in each breadth sequence course. A list of breadth sequences is in the back of this manual.
6. Only one ECE graduate faculty member needs to be appointed to a non-thesis master's supervisory committee.

### 2. Final Examination Procedures - *Master of Science only*

The M.S. non-thesis final examination is a comprehensive test of the student's knowledge in one of the breadth sequences and is offered as part of the second course of the sequence. Professors will have discretion to form the exam in their course. Some suggested formats are:

- Take home question(s) about the course and the student's understanding of the material.
- Extended project that includes material from the first course.
- Extended midterm exam which will include material from the first course of the sequence.
- Take home essay which covers research in breadth sequence.

In case of failure, the exam can be retaken the next time it is offered.

Students must register online in order to take the MS final exam. Online registration opens six weeks prior to the mid-point deadline of the semester.

Students will also be required to complete an Exit Survey during the semester in which they intend to graduate.



### 3. Checklist for Non-thesis Option

✓	To Do	When
	If appropriate, transfer up to 9 credit hours from graduate courses taken previously to your UF master's program.	First semester
	Appoint supervisory committee. This committee must be appointed by the end of the second semester	Second semester
	Take Master's final exam this semester. By the application deadline, register for the exam at the Student Services Office and indicate your selected area.	
	Check with the Student Services Office to see if all graduation requirements, including appropriate course hour credit, will be satisfied.	Semester before graduation
	If you have any grades less than C (i.e. D, I, or E grades), discuss your options for meeting graduation requirements.	
	Submit degree application to the Student Services Office prior to the deadline.	Semester of graduation
	If you have not passed the Master's final exam, take it this semester. By the application deadline, register for the exam at the Student Services Office and indicate your selected area.	
	Complete the Exit Survey.	

# V. Doctor of Philosophy Degree

## 1. Course Requirements and Period of Concentrated Study

For the Ph.D. degree, at least 90 credit hours beyond the bachelor's degree are required. These hours include master's degree work taken at the University of Florida or, if appropriate, up to 30 hours of master's degree work in ECE earned at another approved university. The hours accumulated for the Ph.D. degree have the following restrictions:

- At least 24 hours of 5000, 6000, or 7000 level EEL courses are required. EEL 5905, 6905, 6910, 6932, 6940, 6971, 7979, and 7980 are not considered course work for the purpose of this 24-hour requirement. EEL courses taken in a master's program at UF are automatically included. This course requirement can only be fulfilled by completing EEL course work at the University of Florida.
- All EEL 7980 (Research for Doctoral Dissertation) credit hours are counted. These credits will not count until the student has been officially admitted to candidacy. If the qualifying exam is taken before the midpoint of the term, the Graduate School will change the student's EEL 7979 to EEL 7980. The midpoint of the term is determined by the Graduate School and is published in its "Deadline Dates".
- Fifty percent of all hours accumulated have to be in ECE at the 5000, 6000 or 7000 level (including EEL 7980).
- Completion of the hours stated in the breadth requirement.
- Only 30 hours from the Master's degree may be counted toward the Ph.D. degree.

Candidates for the doctoral degree must satisfy the minimum requirements for a period of concentrated study, beyond the first 30 semester hours counted toward the doctoral program. Students must complete 30 hours in residence on the UF campus or at the Graduate Engineering and Research Center. Courses at the 1000 or 2000 level will not be counted toward the concentrated study requirement.

## 2. Appointment of Supervisory Committee

The supervisory committee is a group of faculty members who supervise and approve qualifications for the Ph.D. degree. The committee should be appointed as soon as possible, but no later than the end of the second semester. The Graduate School may put a hold on the student's record if they do not meet this requirement. The committee consists of four or more members with at least two of the members having Graduate Faculty status in the ECE department. The committee chairperson must have Graduate Faculty status and be from the ECE department. One member of the committee must be from a discipline outside of the department and must maintain graduate faculty status in their respective department.

After the committee has been determined, the student should obtain a Supervisory Committee Form from the Student Services Office (Larsen 230) and have the professors sign the form indicating that they are willing to serve on the committee.

### 3. Ph.D. Course Breadth Requirement

All potential Ph.D. candidates are required to take three ECE breadth sequences and receive a grade of B or higher in each course. A list of the breadth sequences is in the back of this manual.

A total of 18 credits are required. Courses taken at the master's level may be counted if they are in the allowed sequences as shown in the breadth areas.

The student and his/her advisor decide on the appropriate breadth sequences. The student must pass the approved breadth requirements before the oral part of the Ph.D. Qualifying Exam can be taken.

### 4. Leave of Absence Policy

A doctoral student who will not be registered at UF for a period of more than one semester needs to request written permission from his/her faculty advisor for a leave of absence for a designated period of time. A copy of the written permission memo must be taken to the Student Services Office and placed in the student's file.

### 5. Official Minor

With the approval of the supervisory committee, a student may choose one official minor field (minimum 12 graduate credit hours). An official Ph.D. minor **cannot** be used to fulfill a Ph.D. breadth sequence in ECE.

Minor work may be completed in any department, other than ECE, that is approved for master's or doctoral degree programs as listed in the *University of Florida Graduate Catalog* and supports a program that is related to the student's Ph.D. research area.

If an official minor is chosen, the supervisory committee must include a representative from the minor field.

If an official minor is chosen, a representative of the minor department, who may or may not be on the supervisory committee, shall designate at least one 6-hour graduate course sequence in the minor field for written examination. It is the student's responsibility to schedule the exam with the professor in the minor department. The student must pass this exam in order for the minor to be valid. The official minor exam must be completed before the student can be admitted to candidacy.

### 6. Written Portion of the Qualifying Exam

The Ph.D. written qualifying exam is a test reviewing fundamental material that students are expected to have covered before joining the doctoral program. The questions are taken from the following areas of ECE:

- Digital Logic
- Signals and Systems
- Electronic Circuits
- Solid State Devices

- Electromagnetism and Energy Systems
- Microprocessor Applications
- Computer Organization and Architecture
- Data Structures and Operating Systems

Each student selects three areas before the examination and receives two questions in each one of the selected areas. Answers must be given to four of the six questions, including at least one question from each of the three areas. The examination tests problem solving skills, fundamental understanding, reasoning ability, and written communication skills. The test will last for two hours. No materials are allowed during the examination. The department will provide scientific calculators for use during the exam.

The written qualifying exam is offered only once a year in January on a Saturday shortly after the start of Spring classes. Students must sign up for their selected areas in the Student Services Office by the end of November in the preceding year. Detailed study guides will be available in the fall semester.

Students must take the written qualifying exam during their first year in the doctoral program. Financial support may be contingent on taking the exam. Upon failure, the written qualifying exam can be retaken the next time it is offered. If more than two attempts are required, students may petition the Graduate Petitions Committee for permission to retake the exam. A successful petition normally includes a letter of support from the proposed Ph.D. advisor.

Students with a minor in another department have to arrange for a written qualifying exam in their minor to satisfy the Graduate School requirements. The exam must be administered by the student's minor supervisor.

## **7. Oral Portion of the Qualifying Exam**

The oral part of the Ph.D. qualifying exam is usually taken one year after the satisfactory completion of the written portion of the qualifying exam. The oral part of the exam consists of:

- Presenting his/her written research proposal
- Answering questions asked by the supervisory committee and others present

The Student Services Office must be notified at least two weeks in advance of the oral qualifying examination so the Announcement of Examination form can be mailed and the Admission to Candidacy form prepared. This form should be taken to the qualifying exam by the student, signed by the supervisory committee and returned to the Student Services Office for processing.

If the student fails the oral portion of the qualifying exam, s/he may retake it only once and it must be retaken within two semesters.

If a student fails the oral portion of the qualifying examination for a second time, the Graduate School will be notified. A re-examination may be requested but it must be recommended by the student's supervisory committee and approved by the Graduate School. At least one semester of additional preparation is considered essential before re-examination.

Between the date of completion of the qualifying exam and the date of the degree, there must be a minimum of two semesters if the candidate is in full-time residence or a calendar year if the candidate is in attendance on less than a full-time basis. The semester in which the qualifying examination is completed is counted provided that the exam is completed before the midpoint of the

term. No more than five years may pass between the completion of the qualifying exam and the conferring of the degree.

The doctoral student becomes a doctoral candidate when the following requirements are satisfied:

- The student academic record is satisfactory.
- The breadth requirement is completed.
- The Supervisory Committee certifies that the student has made satisfactory progress to be admitted to candidacy.
- The student has a dissertation topic approved by his/her supervisory committee.
- The student has passed both the written and oral portions of the qualifying exam.
- The Admission to Candidacy form has the required formal approvals.

The ECE department requires that the student be admitted to candidacy as soon as the criteria listed above have been met but not later than three years after passing the written portion of the qualifying exam.

## **8. Final Examination and Submission of Dissertation**

The Ph.D. final exam consists of an oral defense of the research results that are described in the doctoral dissertation. This exam is given within six months of graduation, after the first submission of the dissertation, and the completion of all other prescribed work for the degree.

Students must submit the dissertation electronically. Students should refer to the Graduate School Editorial Office for more information regarding their dissertation submission. The guidelines are also online at: (<http://gradschool.rgp.ufl.edu/editorial/introduction.html>)

Electronic submission requires a signed ETD Submission Approval Form, Final Exam Form, and one electronic copy to the Student Services Office.

The Student Services Office should be informed of the examination one week prior to the defense date in order to process the Final Exam Report form and send out notices.

Copies of the student's dissertation must be given to the supervisory committee members at least two weeks in advance of the final examination. Graduation may be delayed for those who do not adhere to this rule.

At the time of the defense, all committee members should sign the signature pages in the dissertation and sign the Final Exam Report form which is to be returned to the Student Services Office. Students will also submit the original copy of their dissertation to the Student Services Office.

Students are also required to complete an Exit Survey during the semester they plan to graduate. Students can find more information about the Exit Survey in the Student Services Office.

All work for the Ph.D. degree must be completed within five calendar years after the completion of the Ph.D. qualifying exam.

## 10. Checklist for Ph.D. Degree

✓	To Do	When
	Appoint supervisory committee. This committee must be appointed by the end of the second semester.	First Year Second Semester
	If appropriate, petition to the Graduate Committee to have non-UF master's course work (30 hours maximum) transferred to the doctoral record.	
	Complete all breadth requirements before taking the oral portion of the qualifying exam.	
	Take the written portion of the qualifying exam.	
	Arrange with the supervisory committee the details of your written research proposal that is to be defended in the oral exam.	Second Year
	If possible, take the oral portion of the qualifying exam within one year of the written portion. You MUST take the oral portion within three years after passing the written portion.	
	At least two weeks in advance of the oral exam, notify, in writing, the Student Services Office of plans to complete the qualifying exam.	
	Pass oral portion of the exam	
	Check with the Student Services Office to see if all graduation requirements, including appropriate course hour credit, will be satisfied.	Semester before graduation
	If you have any grades less than C (i.e. D, I, or E grades), discuss your options from meeting graduation requirements.	
	Submit degree application to the Student Services Office prior to the deadline.	Semester of graduation
	Comply with Graduate School dissertation and final examination deadline dates	
	Be registered for at least the minimum number of dissertation hours (3 hours in the fall and spring semester, 2 hours in the summer)	
	Schedule the doctoral defense with the supervisory committee. Inform the Student Services Office of plans to take the examination, and reserve a conference room. The Student Services Office will send the announcement of exam and prepare the Final Exam Report.	

**Checklist for Ph.D. Degree – *Continued***

✓	To Do	When
	At least two weeks in advance of the final examination, give the supervisory committee members a copy of the dissertation	Semester of graduation
	On the day of the examination, report to the Student Services Office to pick up the necessary forms.	
	Have the Final Examination Report form and the original signature page of the dissertation signed by the supervisory committee members. Return the Final Examination Report form to the Student Services Office.	
	Submit the signed, original copy of the dissertation to the Editorial Office of the Graduate School. Submit an electronic copy to the Student Services Office.	
	Complete the Exit Survey.	

## VI. Administrative Procedures

### 1. Graduate Bulletin Boards

At least once a week, check the ECE Graduate bulletin boards, located outside 230 Larsen Hall, for announcements, changes in course offerings or room schedules, notices of examinations, and for other matters of interest to ECE graduate students.

### 2. Degree Audits

A student's degree audit is a condensed summary of their degree progress. Students can check their degree progress by viewing their degree audit on line at <http://my.ufl.edu/>. Students are expected to periodically review their degree audit to monitor their academic progress. Degree audit should be used in conjunction with advisement resources available in the Student Services Office.

### 3. ECEL Email Accounts

All ECE students are required to have an ECEL email account. The Student Services Office uses the ECEL listserve to deliver important announcements to the students. Students can acquire an ECEL email account by visiting 288 NEB on or after the first day of classes.

### 4. Graduate Registration

Students can register for classes online at <http://my.ufl.edu/>. A guide to the registration system is also online. The Student Services Office is available for help with registration and for registration to departmentally controlled courses.

Graduate students on appointment must register for the appropriate course load as indicated in the table below. Audited courses do not count as part of the hourly requirements for full time students or those on assistantships.

<b>Appointment</b>	<b>Minimum Credit</b>	<b>Maximum Credit</b>
Fellows and Trainees	12	18
1/4 Time Assistants	9	15
1/3 Time Assistants	9	15
1/2 Time Assistants	9	15
3/4 Time Assistants	6	9
Full-Time Assistants	3	3

Graduate students may not, in general, take any course under the S/U option except for certain graduate courses that have only S/U grading (as specified in the Graduate Catalog). Students who complete all graduate degree requirements during a given semester, but after the deadlines specified by the Graduate School, may receive their degree in the following semester without registering. However, students whose degree requirements are not completed before the first day of classes of the following semester must register for a minimum of three credit hours (two credits in the summer term) which will apply to the degree. *The Graduate School will not accept petitions to*



*this policy.* The minimum registration is only applicable if the student is not on assistantship.

## 5. Add/Drop Policy

Graduate students are allowed a limited number of schedule adjustments after the midpoint deadline of the semester. Students are permitted one schedule adjustment after the midpoint deadline per degree program. A schedule adjustment is defined as any of the following: adding a course, dropping a course, and/or switching course work hours for another course (research hours, independent study, etc.). Student's requesting additional adjustments must petition the Graduate Coordinator for approval. A successful petition would require a letter of support from the student's faculty advisor.

## 6. GPA and Probation Policies

In compliance with Graduate School rules, graduate students must maintain a GPA of 3.00 or higher in order to be in good standing. Students cannot graduate if their GPA is below 3.00.

Please note that the term "GPA" includes three different numbers, all of which need to satisfy the requirement of 3.00 or higher.

- The grade point average of **all courses** (3000 level and above) taken while classified as a graduate student;
- The grade point average of **all ECE graduate level courses** taken while classified as a graduate student;
- The grade point average of all graduate level courses that are part of a minor.

An academic hold will be placed on the records of all students whose GPA is below 3.00, thus placing the student on academic probation. These students will be able to register for courses only through the Student Services Office. This will enable our office to provide advice and guidance on an individualized basis.

Students with a GPA below 3.00 must show progress each semester towards improving their GPA, even if it takes more than one semester to reach a GPA of 3.00 or higher.

*Students with a GPA below 3.00 and who do not raise their GPA the following semester will be dismissed from the program.*

## 7. Transfer of Credits

Up to 9 credit hours of graduate level engineering and science courses passed with a grade of B or higher may be transferred from another institution. Students may also petition to transfer graduate level courses which were taken while classified as an undergraduate, postbaccalaureate, or non-degree seeking student, if proof is provided indicating that courses were not used to satisfy degree requirements for another degree. Normally, no more than 15 credits may be transferred into the student's graduate program. Credits obtained in non-degree programs, e.g. continuing education, may not be transferred. Credits transferred will be applied toward meeting the degree requirements, but the grades earned will not be computed in the student's grade point average unless the course work was completed at UF.

Application for transfer of credit earned after admission to a UF graduate program must be filed with

the Graduate School as soon as possible but before the last day of classes preceding the term in which the degree is to be conferred. The student must provide a complete description of the graduate course in consideration for transfer and a transcript indicating the grade earned. The approval of the Graduate Coordinator and the Dean of the Graduate School are required for the acceptance of transfer credits.

## 8. Financial Aid

Applications for teaching assistantships, research assistantships and fellowships are available from the Department of Electrical and Computer Engineering. Fellowships are highly competitive and generally require completed applications by February each year. Recipients of teaching assistantships are selected by the Associate Department Chairman. Research assistantships are awarded by individual faculty members with funding from governmental or industrial sources and are generally awarded only to those students who have been in residence at least one semester.

Minimum stipends and assigned duties for teaching assistants are determined by the Graduate School and are in accordance with the assistantship appointment. Duties include grading, staff meetings, class preparation, student consultation, required lecture attendance, and research not directly related to the student's thesis or dissertation. Students will also have assigned classroom or laboratory teaching responsibilities. International students who wish to be eligible for graduate assistantships must pass the SPEAK (TSE) test. The passing score is 55. Students who score a 45 or 50 must take EAP 5836, Academic Spoken English, but are still allowed to hold a graduate assistantship.

Appointment	Minimum Registration Hours	Minimum Biweekly Rate	Total Hours Per Week
1/4 Time	9	\$196.54	10
1/3 Time	9	\$259.43	13.33
1/2 Time	9	\$393.08	20

## 9. Tuition Waivers

Tuition waivers are awarded to graduate students who have been awarded an assistantship from 1/4 time - 1/2 time. Fee waivers are contingent on the availability of funds. Due to the limit of available funds, no fee waivers are available without assistantship appointments. The waivers are processed under strict guidelines provided by the Graduate School.

## 10. Readmission Procedures

Students who have left the program prior to graduating and wish to be readmitted, require the following:

- A minimum GPA of 3.00 for readmission into the Master's program and a minimum GPA of 3.5 for readmission to the Ph.D. program.
- GRE scores that satisfy the admission requirements of the ECE program in effect at the time of readmission.

- Three letters of recommendation from faculty members in the ECE department.

Readmission is not guaranteed, irrespective of the circumstances that necessitate it.

## VII. Graduate Course Descriptions

Websites for the graduate courses are at [www.ece.ufl.edu/academics/classwebsites.html](http://www.ece.ufl.edu/academics/classwebsites.html) provided the professor requested the addition by emailing the departmental webmaster.

### **CDA 6156 - Advanced Computer Architecture** (3 credits)

Prereq: EEL 5764 or CDA 5155.

Evaluation, study, and comparison of computer systems. Development of formal and informal models of computer architecture.

### **EEL 5182 - State Variable Methods in Linear Systems** (3 credits)

Prereq: EEL 4657

Linear algebra and state variable methods for design and analysis of discrete and continuous linear systems.

### **EEL 5225 - Principles of MEMS** (Micro-Electro-Mechanical Transducers) (3 credits).

Prereq: EEL 3396 or permission of instructor.

Introduction to principles of micro-electro-mechanical devices and systems.

### **EEL 5317C - Introduction to Power Electronics** (3 credits)

Prereq: EEL 3304C, 3396. Coreq: EEL 4657.

Components and circuits for power applications. Switched-mode power supplies.

### **EEL 5320 - Bipolar Analog IC Design** (3 credits)

Prereq: EEL 3304C

Amplifier stages, active loads, output stages, op-amps, feedback, frequency response, compensation.

### **EEL 5322 - VLSI Circuits and Technology** (3 credits)

Prereq: EEL 3396 and EEL 3304.

Introduction to VLSI circuit technology and manufacturing fabrication, device models, layout, parasitics, and simple gate circuits.

### **EEL 5336L - Solid State Technology Laboratory** (1 credit)

Solid-state device fabrication. Safety issues.

### **EEL 5441 - Fundamentals of Photonics** (3 credits)

Prereq: EEL 3396 and 3472.

Review of electromagnetic fields and waves, energy bands in semiconductors, p-n junctions and optical properties of semiconductors. Fundamentals of optical modulators and switches, laser theory, laser characteristics, photodetectors, optical waveguides, and photonic applications.

### **EEL 5451L - Photonics Lab** (2 credits)

Prereq: EEL 4440 or 4445 or 5441.

Experiments in wave optics, acousto-optics, lasers, fiber optics, planar wave guides, and coherent optics.

**EEL 5490 - Lightning** (3 credits)

Prereq: EEL 3472.

Introduction to lightning discharge processes. Electromagnetics relevant to lightning measurements. Applications for determining lightning charge, current, location, and characteristics. Lightning protection.

**EEL 5544 - Noise in Linear Systems** (3 credits)

Passage of electrical noise and signals through linear systems. Statistical representation of random signals, electrical noise, and spectra.

**EEL 5546 - Electronic Countermeasures** (3 credits)

Prereq: EEL 4516 or 5544.

Analysis of electronic countermeasures for radar systems. Pulsed and spread spectrum detection; barrage, incoherent, and coherent jammers; burn through analysis; autocorrelation receiver structures.

**EEL 5547 - Introduction to Radar** (3 credits)

Prereq: EEL 4516 or 5544.

Basic principles of cw and pulsed radar; angle, range, and doppler tracking; accuracy and resolution; signal design.

**EEL 5666C - Intelligent Machines Design** (4 credits)

Prereq: EEL 4744C.

Design simulation, fabrication, assembly, and testing of intelligent robotic machines.

**EEL 5701 - Foundations of Digital Signal Processing** (3 credits)

Analysis and design of digital filters for discrete signal processing; spectral analysis; fast Fourier transform.

**EEL 5718 - Computer Communications** (3 credits)

Prereq: EEL 4514.

Design of data communication networks: modems, terminals, error control, multiplexing, message switching, and data concentration.

**EEL 5745C - Microcomputer Hardware and Software** (4 credits)

Prereq: EEL 3701C and EEL 3304C or 3003.

Functional behavior of microprocessors, memory, peripheral support integrated circuit hardware; microcomputer system and development software; applications.

**EEL 5764 - Computer Architecture** (3 credits)

Prereq: EEL 4713C, 4744C, or equivalents.

Fundamentals in design and quantitative analysis of modern computer architecture and systems, including instruction set architecture, basic and advanced pipelining, superscalar and VLIW instruction-level parallelism, memory hierarchy, storage, and interconnects.

**EEL 5840 - Elements of Machine Intelligence** (3 credits)

Engineering and hardware concepts pertaining to design of intelligent computer systems.

**EEL 5905 - Individual Work** (1-4 credits per section number); (max: 6 credits count toward graduation)

Prereq: consent of adviser.

Selected problems or projects.

**EEL 5934 - Special Topics in Electrical and Computer Engineering** (1-3 credits per section number; max: 18 credits count toward graduation)

**EEL 6171 - Advanced System Theory** (4 credits)

Structural analysis of linear dynamical systems. Invariance, F and G invariance, constrained reachability, pole assignment and stability, advanced topics in linear algebra useful in mathematical system theory.

**EEL 6264 - Advanced Electric Energy Systems** (3 credits)

Prereq: consent of instructor. Energy systems planning and operation with emphasis on advanced analysis methodologies and computer simulation.

**EEL 6265 - Advanced Electric Energy Systems II** (3 credits)

Prereq: EEL 6264.

Continuation of EEL 6264 with additional emphasis given to the new electric energy technologies.

**EEL 6321 - MOS Analog IC Design** (3 credits)

Prereq: EEL 5320 or EEL 6311.

Design of analog circuits in CMOS IC technologies. MOS switches, MOS op-amps, circuit simulation using SPICE.

**EEL 6323 - Advanced VLSI Design** (3 credits)

Prereq: EEL 5322.

Advanced very large scale integrated circuit design, testability, and performance evaluation. Use of industrial VLSI software. Building an advanced CMOS VLSI circuit.

**EEL 6324 - Silicon Fabrication Processes** (3 credits)

Prereq: EEL 5322.

Advanced modeling of physics of silicon fabrication. Lithography, deposition, etching, oxidation, implantation, and diffusion. Oriented toward silicon device fabrication.

**EEL 6325 - Computer Simulation of Integrated Circuits and Devices** (3 credits)

Prereq: Graduate standing.

Basic methods of numerical simulation of semiconductor devices and electronic circuits with reference to PISCES and SPICE. PDE discretization; numerical integration, Newton/iterative linearization, linearized system solution.

**EEL 6328C - Microwave IC Design** (3 credits)

Fundamentals of microwave integrated circuit design. Use of computer software to design simple microwave circuits. Microwave circuit testing.

**EEL 6374 - Radio Frequency (RF) Integrated Circuits and Technology** (3 credits)

Prereq: EEL 5322, 4306 or equivalent.

Requirements for RF integrated circuits. Design and implementation. Interdependence of RF circuit performance with devices, parasitics, packages, and process technology.

**EEL 6382 - Semiconductor Physical Electronics I (3 credits)**

Crystal structures; imperfections; statistics; lattice dynamics; energy band theory. Equilibrium properties of electrons and holes in semiconductors. Electronic transport phenomena. Boltzmann's equation and transport coefficients in semiconductors.

**EEL 6383 - Semiconductor Physical Electronics II (3 credits)**

Prereq: EEL 6382.

Scattering mechanisms. Recombination-generation and trapping processes; optical properties. Excess carrier phenomena. Photoelectric effects in semiconductors. Metal-semiconductor contacts. Optoelectronic devices. Junction and MOS devices. Superconductors and Josephson Junction devices.

**EEL 6390 - VLSI Device Design (3 credits)**

Criteria and tradeoffs involved in design of high-performance semiconductor devices in scales (VLSI) Si-based integrated-circuit technologies.

**EEL 6397 - Semiconductor Device Theory I (3 credits)**

Prereq: EEL 3396.

Semiconductor material properties, equilibrium and nonequilibrium processes, quasi-Fermi levels, pn junctions; charge-control modeling; high level injection, heavy doping effects.

**EEL 6398 - Semiconductor Device Theory II (3 credits)**

Prereq: EEL 6397.

Basic mechanisms in bipolar junction transistors, low- and high-current effects; fundamental principles of the MOS system, surface effects on pn junctions, MOS field-effect transistors.

**EEL 6443 - Integrated and Fiber Optics (3 credits)**

Prereq: EEL 5441.

Review of electromagnetic waves. Dielectric interfaces, propagation in graded-index media, slab waveguides, coupled waveguides, waveguide fabrication and characterization.

**EEL 6447 - Laser Electronics (3 credits)**

Prereq: EEL 3473 and EEL 5441 or equivalent.

Study of lasers from basic principles to operational characteristics.

**EEL 6486 - Electromagnetic Field Theory and Applications I (3 credits)**

Prereq: undergraduate course in fields and waves. Advanced electrostatics, magnetostatics, time-varying electromagnetic fields, wave propagation, waveguides.

**EEL 6487 - Electromagnetic Field Theory and Applications II (3 credits)**

Prereq: EEL 6486.

Electromagnetic radiation, antennas, wave propagation in an isotropic media.

**EEL 6502 - Adaptive Signal Processing (3 credits)**

Prereq: EEL 5544, EEL 5701.

Theory of adaptation with stationary signals; performance measures. LMS, RLS algorithms. Implementation issues and applications.

**EEL 6503 - Spread Spectrum (3 credits)**

Prereq: EEL 5544 and EEL 6535.

Techniques and applications; spreading sequence design; code division multiple access; multi-user detection.

**EEL 6507 - Queueing Theory and Data Communications (3 credits)**

Prereq: EEL 5544.

Introduction to basic Queueing models; performance analysis of multiple access protocols; error control strategies.

**EEL 6509 - Wireless Communications (3 credits)**

Prereq: EEL 5544.

Introduction. Satellite and cellular systems, propagation, modulation techniques, multiple access techniques, channel coding, speech and video coding, and wireless computer networks.

**EEL 6524 - Statistical Decision Theory (3 credits)**

Prereq: EEL 5544.

Hypothesis testing of signals in the presence of noise by Bayes, Neyman-Pearson, minimax criteria; estimation of signal parameters.

**EEL 6535 - Digital Communication (3 credits)**

Prereq: EEL 5544.

Optimum receiver principles; analysis of digital and analog communication systems in the presence of noise; modeling of communication channels.

**EEL 6537 - Spectral Estimation (3 credits)**

Prereq: EEL 5544 and EEL 5701.

Measurement and analysis of signals and noise. Digital filtering and spectral analysis; fast Fourier transform.

**EEL 6548 - Radar I (3 credits)**

Basic concepts, wave propagation, antennas, radar equation, cross section, radar signals, detection.

**EEL 6550 - Error Correction Coding (3 credits)**

Prereq: EEL 5544 or equivalent; Coreq: EEL 5544 or EEL 4516.

Introduction to abstract algebra, block coding and decoding, convolutional coding and decoding, trellis coded modulation, run-length-limited codes.

**EEL 6562 - Image Processing and Computer Vision (3 credits)**

Pictorial data representation; feature encoding; spatial filtering; image enhancement; image segmentation; cluster seeking; two-dimensional z-transforms; scene analysis; picture description language; object recognition; pictorial database; interactive graphics; picture understanding machine.

**EEL 6586 - Automatic Speech Processing (3 credits)**

Prereq: EEL 5701.

Various models of speech production and perception. Operation of speech synthesizers. Discussion of speech recognition. Mathematical models of speech signals.

**EEL 6591 - Wireless Networks (3 credits)**

Prereq: EEL 5718 and knowledge of probability and statistics.

Design and analysis of wireless networks including channel characteristics, physical layer, cellular concepts, multiple access control protocols, FEC and ARQ protocols, resource allocation, and wireless standards.



**EEL 6614 - Modern Control Theory I (3 credits)**

Prereq: EEL 5182.

Optimization of systems using the calculus of variations, dynamic programming, and the maximum principle. Extensive study of the linear plant with a quadratic performance index. Observers and dynamic compensators.

**EEL 6617 - Linear Multivariable Control (3 credits)**

Prereq: EEL 5182, MAS 4105.

Transfer matrix theory of systems, emphasis on feedback, internal stability, model matching and the assignment of invariant factors.

**EEL 6619 - Robust Control Systems (3 Credits)**

Prereq: EEL 5182.

Analysis and design of multivariable control systems in presence of uncertainties.

**EEL 6667 - Kinematics and Dynamics of Robot Manipulators (3 credits)**

Algebraic formulation of robot manipulator motion. Homogeneous matrices. Methods for computing forward and reverse kinematic solutions of robot manipulators. Robot differential displacements and Jacobians. Newton-Euler and Lagrangian derivations of manipulator dynamics.

**EEL 6668 - Intelligent Robot Manipulator Systems (3 credits)**

Prereq: EEL 6667.

Trajectory planning and computation for robot manipulators. Splines. Force compliance and hybrid control. Machine perception and intelligence: touch, vision, collision avoidance, automatic task planning. Modeling a robotic manufacturing work cell. Robot computer languages.

**EEL 6702 - Digital Filtering (3 credits)**

Prereq: EEL 5701.

Introduction to number transforms, complexity of algorithms, and finite fields. Development of transforms and digital filters using algebraic operators and finite fields plus the technological consideration of DSP systems and system integration.

**EEL 6706 - Fault Tolerant Computer Architecture (3 credits)**

Prereq: EEL 5764 or CDA 5155.

Design and quantitative analysis of fault tolerant architectures and dependable systems including fundamental issues, redundancy techniques, evaluation methods, design methodology, and applications.

**EEL 6763 - Parallel Computer Architecture (3 credits)**

Prereq: EEL 5764.

Advanced architecture emphasizing design and quantitative analysis of parallel architecture and systems, including theory, hardware technologies, parallel and scalable architectures, and software constructs.

**EEL 6767 - Database Engineering (3 credits)**

Prereq: EEL 4713C.

Architecture of database management system, data models and languages, design, integrity, security, concurrency control, distributed database management.

**EEL 6769 - Hardware-Software Interactions: Nonnumeric Processing (3 credits)**

Prereq: EEL 6767, COP 5725 or consent of instructor.

Information representations; content and context search methods; associative memories, retrieval language mapping; parallel processing; hardware and software garbage collections.

**EEL 6785 - High-Performance Computer Networks (3 credits)**

Prereq: EEL 5718 or CEN 6505.

Design and quantitative analysis of high-speed networks and interconnects including protocols, hardware and software interfaces, switching, light-weight communication layers, flow and error control, and quality of service.

**EEL 6814 - Neural Networks for Signal Processing (3 credits)**

Prereq: EEL 5701.

Optimal filters in vector spaces. Linear machines and discriminant functions. Gradient descent learning in the additive neural model. Performance measures of multilayer perceptions and Hopfield networks. Dynamic neural networks and the issues of short term memory. Unsupervised learning networks.

**EEL 6825 - Pattern Recognition and Intelligent Systems (3 credits)**

Decision functions; optimum decision criteria; training algorithms; unsupervised learning; feature extraction, data reduction; potential functions; syntactic pattern description; recognition grammars; machine intelligence.

**EEL 6841 - Machine Intelligence and Synthesis (3 credits)**

Prereq: EEL 5840.

Theory of machine intelligence applied to general problems of engineering intelligent computer systems and architectures. Applications emphasized.

**EEL 6892 - Virtual Computers (3 credits)**

Prereq: EEL 5764 or COP 5615 or equivalents.

Techniques for virtualization of networked computer systems. Virtual machines (classic Vms, application binary interface Vms, para-virtualization) virtual distributed file systems (file system proxies, call-forwarding) virtual networks (tunneling, virtual private networks).

**EEL 6905 - Individual Work (1-4 credits\*; max: 6 credits.\*\*)**

Prereq: consent of advisor.

Selected problems or projects.

**EEL 6910 - Supervised Research (1-5 credits\*\*\*; max: 3 credits.\*\*)** S/U grading.

**EEL 6935 - Special Topics in Electrical and Computer Engineering (1-4 credits\*; \*\*)**

Topics vary.

**EEL 6940 - Supervised Teaching (1-5 credits\*\*\*; max: 3 credits.\*\*)** S/U grading.

**EEL 6971 - Research for Master's Thesis (1-15 credits\*, max: 6 credits\*\*) S/U grading.**

**EEL 6972 - Research for Engineer's Thesis (1-15 credits\*) S/U grading.**

**EEL 7936 - Advanced Topics in Electrical and Computer Engineering (1-4 credits\*; \*\*)**

**EEL 7979 - Advanced Research (1-12 credits\*)**

Research for doctoral students before admission to candidacy. Designed for students with a master's degree in the field of study or for students who have been accepted for a doctoral program. Not open to students who have been admitted to candidacy. S/U grading.

**EEL 7980 - Research for Doctoral Dissertation (1-15 credits\*) S/U grading.**

\* per section number.

\*\* count for graduation.

\*\*\* no more than five hours may be taken.

\*\*\*\* maximum of 18 credit hours of EEL 5934, EEL 6935, EEL 7936.

# VIII. Graduate Division Flow Diagrams

## 1. Computer Engineering Division

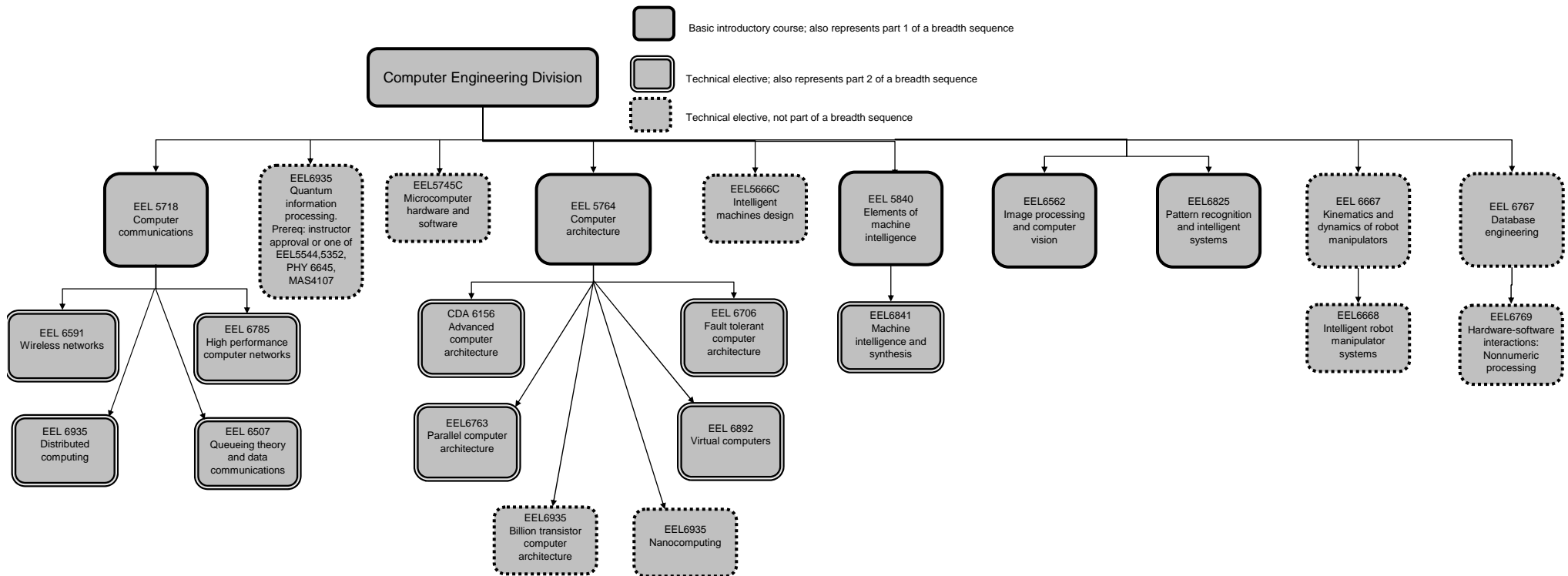

## 2. Devices Division

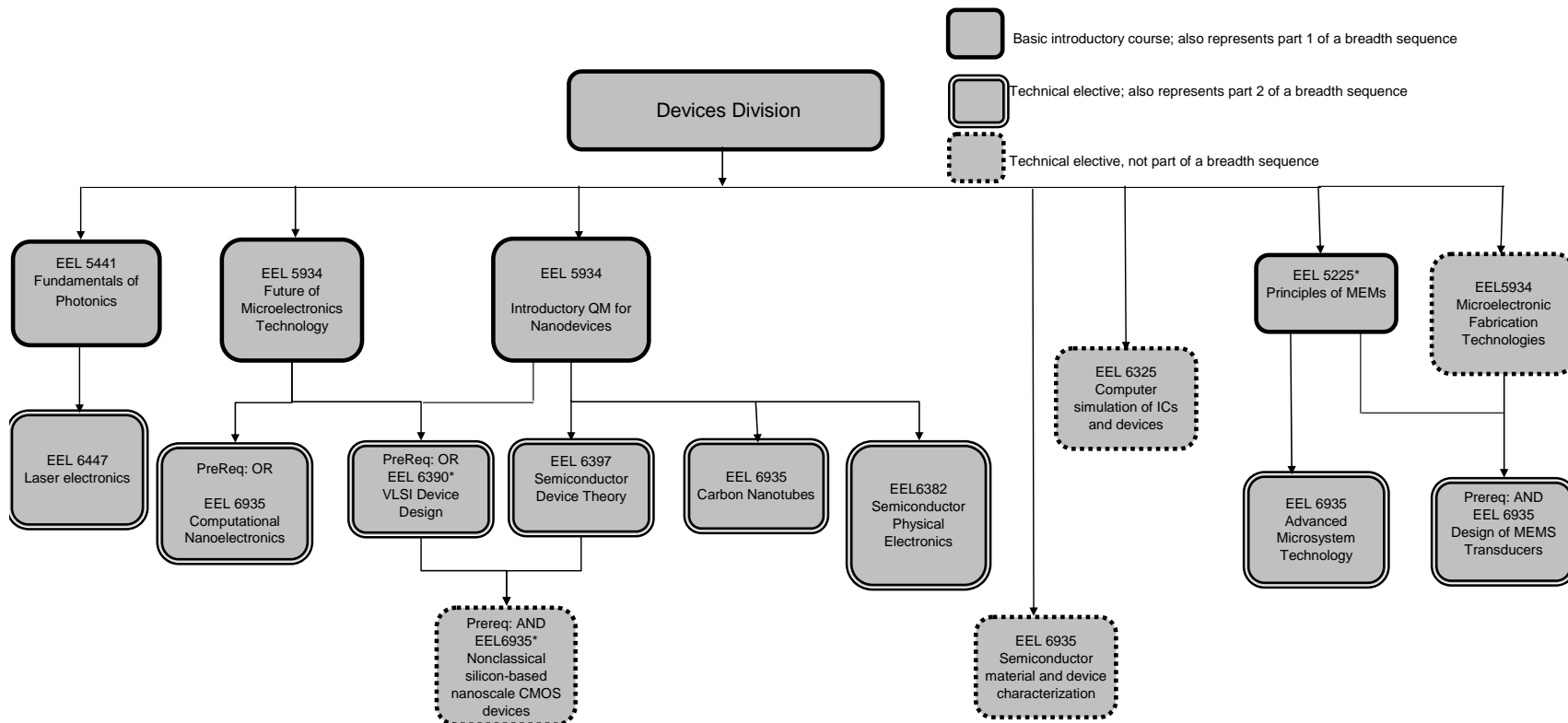

\*Also with consent of instructor

### 3. Electromagnetics & Energy System

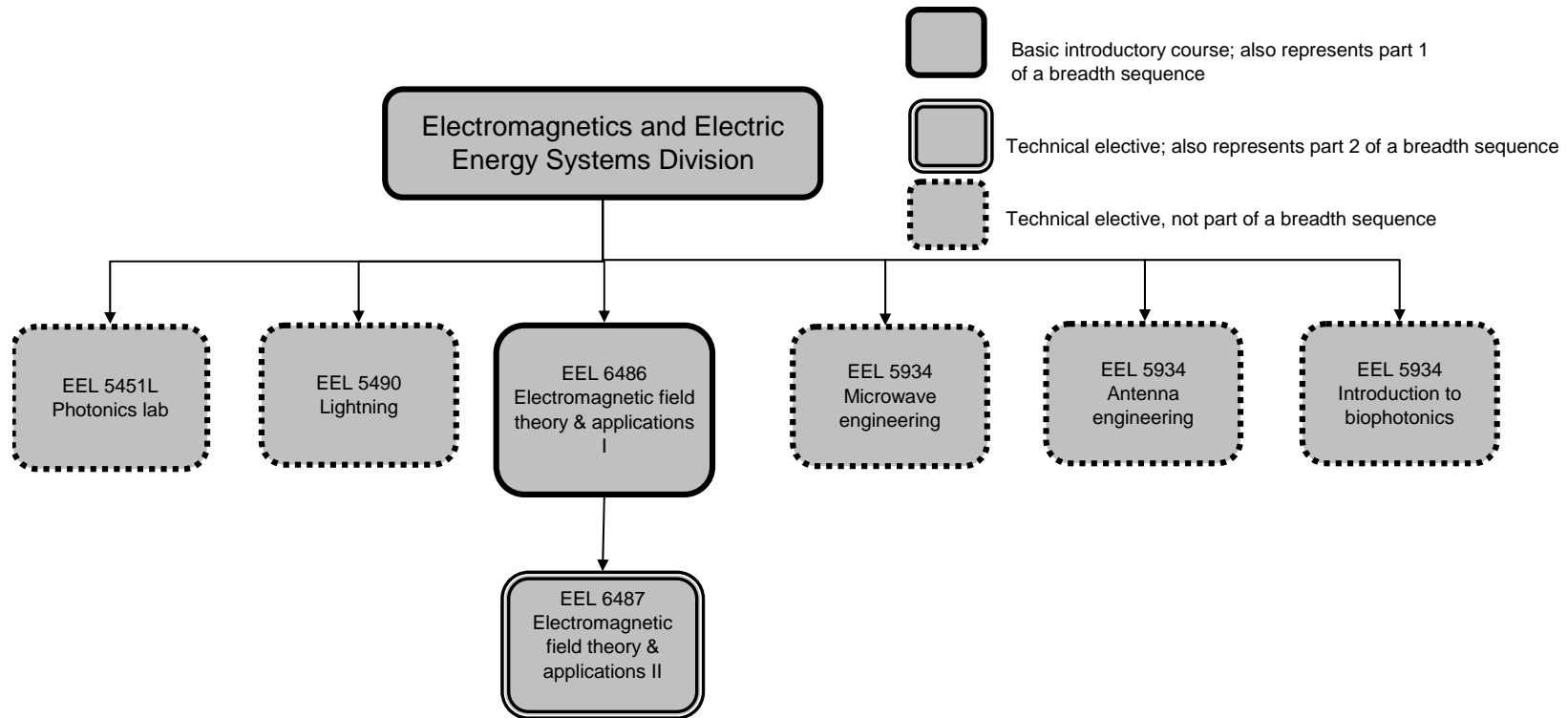

## 4. Electronics Division

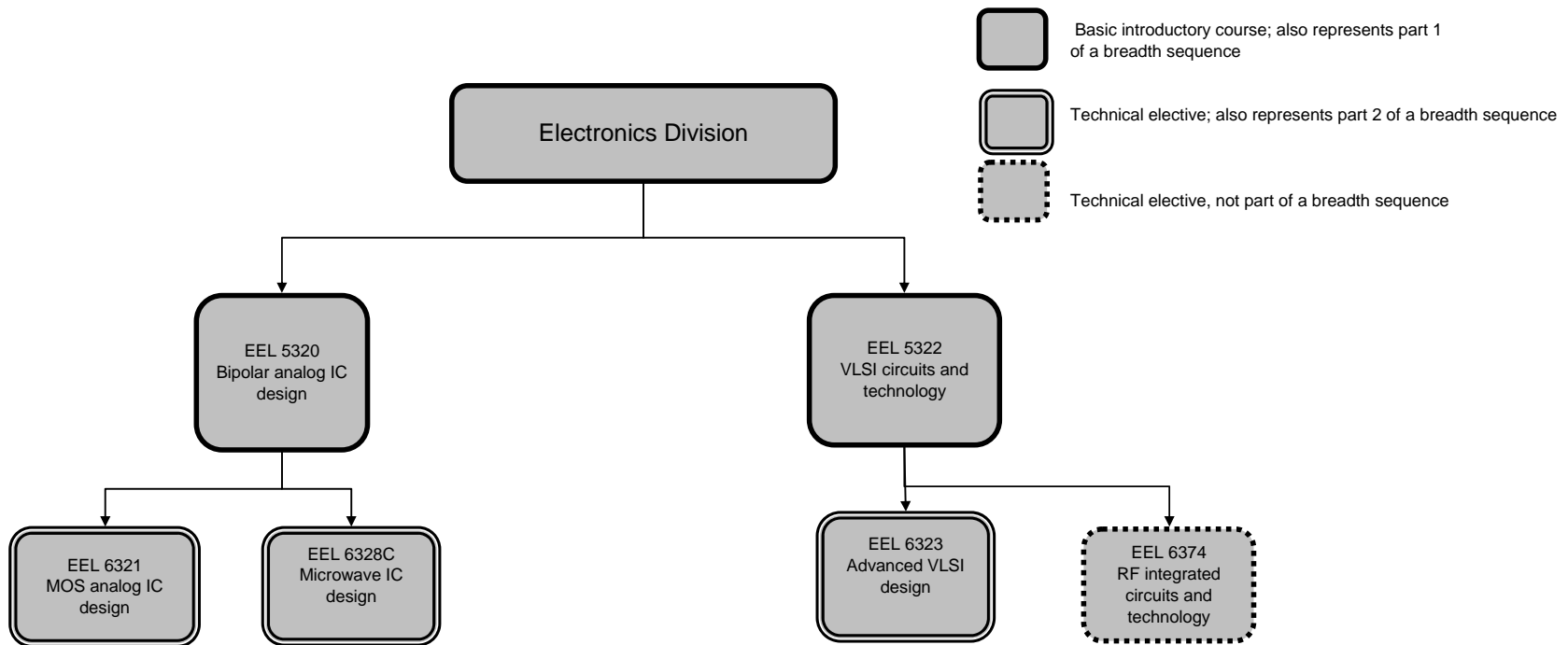







## VIII. Breadth Sequences

A breadth sequence consists of two specific courses. Generally, the first course listed in the breadth sequence should be taken prior to taking the follow-up course.

Area	First Semester		Second Semester
<b>Computer Engineering</b>	EEL 5718	→	Choose one: EEL 6591, EEL 6785 or EEL 6935 (Distributed Computing)
	EEL 5764	→	Choose one: CDA 6156, EEL 6706, EEL 6763 or EEL 6892
	EEL 5840	→	EEL 6841
	EEL 6562	→	EEL 6825
<b>Devices</b>	EEL 5225	→	Choose one: EEL 6935 (Ad. Microsystem Tech.) or EEL 6935 (Design of MEMs Transducers)
	EEL 5441	→	EEL 6447
	EEL 5934 (Future Microelec. Tech.)	→	<b>Choose one*:</b> EEL 6390 or EEL 6935 (Computational Nanoelectronics)
	EEL 5934 (Intro. QM for Nanodevices)	→	<b>Choose one*:</b> EEL 6382, EEL 6390, EEL 6935(Computational Nanotechnology), EEL 6935 (Carbon Nanotubes) or EEL 6937  <b>*Each course can only be used to fulfill one breadth sequence*</b>
<b>Electromagnetics &amp; Energy Systems</b>	EEL 6486	→	EEL 6487
<b>Electronics</b>	EEL 5320	→	Choose one: EEL 6321 or EEL 6328C
	EEL 5322	→	EEL 6323
<b>Signals &amp; Systems</b>	EEL 5182	→	Choose one: EEL 6134, EEL 6614, EEL 6617 or EEL 6619
	EEL 5544	→	EEL 6535
	EEL 5701	→	Choose one: EEL 6502, EEL 6537, EEL 6586 or EEL 6702