

Graduate Guidelines

Department of
Electrical and Computer Engineering

Graduate Guidelines

Department of Electrical and Computer Engineering

University of Florida
P. O. Box 116200
Gainesville, FL 32611

Revised Fall 2011

Department Administration:

John Harris
Department Chair

Robert M. Fox
Associate Chair

Gijs Bosman
Graduate Coordinator
565 NEB
(352) 392-9758
Email: gbosm@ece.ufl.edu

For Information:

Shannon Chillingworth
Student Services Office
230 Larsen Hall
P. O. Box 116200
University of Florida
Gainesville, FL 32611
(352) 392-9758
Email: schill@ece.ufl.edu

Table of Contents

I. Graduate Faculty and Research Areas	4
1. Computer Engineering	4
2. Devices	5
3. Electromagnetics and Electric Energy Systems	6
4. Electronics.....	7
5. Signals & Systems	8
II. Introduction	10
1. Degree Requirements	11
2. Articulation Requirements	12
III. Master's Degree - Thesis Option	13
1. Course Requirements	13
2. Appointment of Supervisory Committee	14
3. Submission of Master's Thesis	14
4. Final Examination Procedures	14
5. Checklist for Thesis Option	15
IV. Master's Degree - Non-thesis Option	16
1. Course Requirements	16
2. Final Examination Procedures - <i>Master of Science only</i>	17
3. Checklist for Non-thesis Option	18
V. Doctor of Philosophy Degree	19
1. Course Requirements and Period of Concentrated Study.....	19
2. Appointment of Supervisory Committee	20
3. Leave of Absence Policy.....	20
4. Official Minor	20
5. Written Portion of the Qualifying Exam	20
6. Oral Portion of the Qualifying Exam.....	21
7. Final Examination and Submission of Dissertation.....	22
8. Checklist for Ph.D. Degree	24
VI. Administrative Procedures	26
1. Graduate Bulletin Boards	26
2. Degree Audits	26
3. Gatorlink Email Accounts.....	26
4. Graduate Registration	26
5. Add/Drop Policy	27
6. GPA and Probation Policies.....	27
7. Transfer of Credits	27
8. Internship Policy.....	28
9. Financial Aid.....	29
10. Tuition Waivers	29
11. Assistantships While on Internship	29
12. Readmission Procedures.....	30
VII. Graduate Course Descriptions	31
VIII. Graduate Division Flow Diagrams	38

I. Graduate Faculty and Research Areas

1. Computer Engineering

This division focuses on the theoretical and applied research by which next-generation computing and communications systems are designed, developed, and exploited. Research fields include high-performance computer architectures, computer networks, wireless networks, mobile computing, social networks and computing, privacy and security, parallel and distributed systems, reconfigurable systems, fault-tolerant computing, real time and embedded systems, and intelligent systems.

Antonio Arroyo

PhD, University of Florida, 1981. Machine intelligence, artificial intelligence, microprocessors, microcomputers, expert systems, human-machine interaction, computer software and hardware systems, pattern recognition, digital signal / natural language and speech processing

Yuguang (Michael) Fang

Ph.D., Boston University, 1997. Wireless networks and mobile communications; personal communication services (PCS).

Renato Figueiredo

PhD, Purdue University, 2001. Computer architecture, network computing, distributed systems.

Jose A. B. Fortes

BellSouth Eminent Scholar Chair; PhD, University of Southern California, 1984. Network computing, advanced computing architecture, biologically inspired nanocomputing, distributed information processing systems.

Alan George

PhD, Florida State University, 1991. High-performance computer networks, architectures, systems, algorithms, and services for applications in parallel, distributed, reconfigurable, and fault-tolerant computing.

Ann Gordon-Ross

PhD, University of California- Riverside, 2007. Low-power design, reconfigurable computing, platform design, dynamic optimizations, hardware design, real-time systems, and multi-core platforms.

Herman Lam

PhD, University of Florida, 1979. Computer engineering, database management and computer architecture.

Haniph A. Latchman

PhD, Oxford University, 1986. Mathematical systems theory, control systems, communication theory, data communication networks, multimedia information systems.

Tao Li

PhD, University of Texas at Austin, 2004. Computer and digital system architecture; interaction of computer architecture, emerging applications, operating systems, programming language features, managed run-time environments; modeling, simulation and evaluation of computer systems.

Xiaolin (Andy) Li

PhD, Rutgers University, 2005. Parallel and Distributed Systems (PDS) and Cyber-Physical Systems (CPS), focusing on design of scalable algorithms and software systems to enable large-scale applications.

Janise McNair

PhD, Georgia Institute of Technology, 2000. Wireless and mobile networking, next generation wireless systems, medium access control protocols.

Kamran Mohseni

PhD, California Institute of Technology, 2000. Aerial and underwater vehicle control, autonomous systems, cooperative control, mobile wireless sensor networks, and microfluidic devices.

Greg Stitt

PhD, University of California- Riverside, 2007. Embedded systems with an emphasis in synthesis, compilers, reconfigurable computing, hardware/software co-design, low power-design, system-on-chip multi-core architectures, real-time systems, and run-time optimizations.

Dapeng Wu

PhD, Carnegie Mellon University, 2003. Wireless communications, video coding, multimedia communication, computer and communication networks, information and network security, pervasive and mobile computing, information and communication theory, signal processing, detection and estimation theory.

2. Devices

The device division focuses on the behavior, fabrication, and design of devices. These include optoelectronics (solar cells and detectors), transistors (SiGe, MIS, III-V), MEM's (mechanical, optical, biological sensors), and nanodevice concepts (CNT, Molecular, Silicon-based). There is research on both how materials interact with voltage, current, photons, and radiation as well as the current-voltage relationship of device structures.

David P. Arnold

PhD, Georgia Institute of Technology, 2004. Design, fabrication, and characterization of magnetic and electromechanical microsensors/microactuators, as well as miniaturized power and energy systems

Gijs Bosman

Graduate Coordinator, Ph.D., State University of Utrecht (Netherlands), 1981. Electronic noise research, solar cells, device reliability, and quantum devices.

Jerry G. Fossum (Emeritus)

PhD, University of Arizona, 1971. Semiconductor device theory, modeling, and simulation; nanoelectronics, integrated circuits (ICs), IC technology computer-aided design (TCAD); silicon-on-insulator (SOI) and double-gate (DG) CMOS lcs.

Jing Guo

PhD, Purdue University, 2004. Modeling and simulation of nanoelectronic devices, carbon nanotube electronics and photonics, physics of nanotransistors, computational nanobiotechnology.

Mark E. Law

Associate Dean of Academic Affairs, PhD, Stanford University, 1988. Design and modeling of IC fabrication process, computer modeling of semiconductor process and device behavior, numerical solution of partial differential equations.

Arnost Neugroschel (Emeritus)

PhD, Technion, Israel Institute of Technology, 1973. Semiconductor device physics, device technology and characterization.

Toshikazu Nishida

PhD, University of Illinois-Urbana, 1988. Semiconductor sensors and devices

Scott Thompson

PhD, University of Florida, 1992. Solid state electronics and nano technology, new materials and devices to extend Moore's law, Electrical measurements and modeling of strained Si, Ge, GaN semiconductors.

Ant Ural

PhD, Stanford University, 2001. Carbon nanotubes, semiconductor nanowires, and related nanostructures. Integration of nanotechnology with silicon microfabrication processes. Molecular electronics, nanoscale MEMS, and nanobiotechnology.

Huikai Xie

PhD, Carnegie Mellon University, 2002. Semiconductor devices, integrated microsensors and microactuators, optical MEMS, biosensors, biomedical imaging, fiber optics, micro/nano fabrication technology, and multi-domain simulation.

Yong-Kyu (YK) Yoon

PhD, Georgia Institute of Technology, 2004. 3-D MEMS technology; micromachined metamaterials for radio frequency and microwave applications; millimeter-wave antennas and waveguides; lab-on-a-chip type bio/microfluidic systems; anodized nanoporous membranes and electrospun nanofibers for its bio/optical applications; microsensors and actuators; electronic and MEMS packaging; and ferroelectric materials and their RF applications.

Peter Zory (Emeritus)

PhD, Carnegie-Mellon University, 1964. Semiconductor lasers physics and technology.

3. Electromagnetics and Electric Energy Systems

This division spans a wide area of research of electromagnetic fields and their application. It includes electromagnetic interaction with matter, guided wave devices, fiber optic communications, and photonic devices and systems. UF is one of the few universities in the world conducting lightning research. Experiments on lightning physics and lightning protection are performed each summer both on the UF campus and at Camp Blanding, Florida.

David P. Arnold

PhD, Georgia Institute of Technology, 2004. Design, fabrication, and characterization of magnetic and electromechanical microsensors/microactuators, as well as miniaturized power and energy systems.

Jenshan Lin

PhD, University of California- Los Angeles, 1994. Microwave/millimeter-wave electronics and wireless communication circuits, high speed electronics and broadband communication circuits.

Robert Moore

PhD, Stanford University, 2006. Electromagnetic waves, non-linear energetic interactions in the ionosphere, remote-sensing applications of ELF/VLF wave propagation in the Earth-ionosphere waveguide.

Vladimir A. Rakov

PhD, Tomsk Polytechnic Institute, 1983. Lightning, atmospheric electricity, lightning protection.

Ramakant Srivastava (Emeritus)

PhD, Indiana University, 1973. Integrated optics and waveguide sensors.

Martin A. Uman

PhD, Princeton University, 1961. Lightning, atmospheric electricity, electromagnetics.

Henry Zmuda

Undergraduate Coordinator, PhD, Cornell University, 1984. RF/Microwave photonic systems, optically controlled phased array antennas, phased array signal processing, photonic high speed analog-to-digital conversion.

Peter Zory (Emeritus)

PhD, Carnegie-Mellon University, 1964. Semiconductor lasers physics and technology.

4. Electronics

This division covers a broad range of topics from the design and manufacturing of integrated circuits to their applications in real world systems. Current research includes mixed-signal electronics, data converters, biomedical circuits and systems, integrated power management, low power VLSI design, radio frequency and microwave circuits, IC test and validation, and modeling of materials, components, and circuits for high-frequency power electronics.

Rizwan Bashirullah

PhD, North Carolina State University, 2004. Circuit design techniques for high-performance analog/digital VLSI, electronic circuit devices and technology, high-speed signaling techniques and circuits for biomedical applications.

William R. Eisenstadt

PhD, Stanford University, 1986. Microwave integrated circuits, IC packages, VLSI, high-frequency measurements, mixed-mode s-parameters.

Robert M. Fox

Associate Chair, PhD, Auburn University, 1986. Analog electronic circuit design.

Qun (Jane) Gu

Ph.D., University of California-Los Angeles, 2007. RF/MMIC/THz and mixed signal integrated circuits and systems, as well as system-on-chip techniques for high reliability and low power consumption.

John G. Harris

Chair, PhD, California Institute of Technology, 1991. Analog and digital signal processing, VLSI, adaptive and neural systems.

Mark E. Law

Associate Dean of Academic Affairs, PhD, Stanford University, 1988. Design and modeling of IC fabrication process, computer modeling of semiconductor process and device behavior, numerical solution of partial differential equations.

Jenshan Lin

PhD, University of California-Los Angeles, 1994. Microwave/millimeter-wave electronics and wireless communication circuits, high speed electronics and broadband communication circuits.

Nima Maghari

PhD, Oregon State University, 2010. High performance data converters, delta-sigma modulators, synthesizable analog to digital converters, data converters for biomedical applications, time assisted conversion techniques.

Scott Thompson

PhD, University of Florida, 1992. Solid state electronics and nano technology, new materials and devices to extend Moore's law, Electrical measurements and modeling of strained Si, Ge, GaN semiconductors.

Yong-Kyu (YK) Yoon

PhD, Georgia Institute of Technology, 2004. 3-D MEMS technology; micromachined metamaterials for radio frequency and microwave applications; millimeter-wave antennas and waveguides; lab-on-a-chip type bio/microfluidic systems; anodized nanoporous membranes and electrospun nanofibers for its bio/optical applications; microsensors and actuators; electronic and MEMS packaging; and ferroelectric materials and their RF applications.

5. Signals & Systems

Studies in this field are related to the transmission, creation, manipulation, and understanding of signals and systems. Signal processing looks to take data from a wide variety of sources (speech, audio, images, video, radar, sensor networks) and transforming it into useable pieces.

Communication systems are designed to transmit information while minimizing the corruptive effects of noise and interference.

Jacob Hammer

D. Sci., Technion, Israel Institute of Technology, 1980. Mathematical system theory, control systems.

John G. Harris

Chair, PhD, California Institute of Technology, 1991. Analog and digital signal processing, VLSI, adaptive and neural systems.

Pramod P. Khargonekar

Eckis Professor, PhD, University of Florida, 1981. Systems and control theory, learning and intelligent systems, biomedical, engineering, and economics applications, leadership and creativity, technology and society.

Haniph A. Latchman

PhD, Oxford University, 1986. Mathematical systems theory, control systems, communication theory, data communication networks, multimedia information systems.

Jian Li

PhD, Ohio State University, 1991. Signal processing for wireless communications and radar.

Kamran Mohseni

PhD, California Institute of Technology, 2000. Aerial and underwater vehicle control, autonomous systems, cooperative control, mobile wireless sensor networks, and microfluidic devices.

Jose C. Principe

PhD, University of Florida, 1979. Adaptive non-Gaussian signal processing, nonlinear dynamical systems, information-theoretic learning, applications to pattern recognition and DSP systems, information technology in education.

John M. Shea

Ph.D., Clemson University, 1998. Wireless communications, adaptive modulation and coding, multicast signaling, multimedia transmission over wireless channels, channel-quality estimation, spread spectrum communications.

Fred J. Taylor (Emeritus)

PhD, University of Colorado, 1969. Digital signal processing, digital computer design and architecture.

Tan F. Wong

Ph.D., Purdue University, 1997. Wireless communications, spread spectrum systems, multiuser communications, adaptive signal processing.

Dapeng Wu

PhD, Carnegie Mellon University, 2003. Wireless communications, video coding, multimedia communication, computer and communication networks, information and network security, pervasive and mobile computing, information and communication theory, signal processing, detection and estimation theory.

II. Introduction

The graduate program of the Department of Electrical and Computer Engineering at the University of Florida offers the Master of Engineering (M.E.), Master of Science (M.S.), and Doctor of Philosophy (Ph.D.) degrees. The Graduate Guidelines detail the policies and regulations governing the Master of Engineering, Master of Science, and Doctor of Philosophy programs and should be used in conjunction with the University of Florida *Graduate Catalog*. It is the responsibility of the student to be familiar with both publications and to adhere to the stated rules and policies.

More information regarding the Joint MS/MSM, Joint JD/MS, and other degree program options can be found on the web at <http://www.ece.ufl.edu/academics/graduate/jointdegrees/main.html>.

1. General Degree Requirements

For the Master's degree, a minimum of 30 credit hours is required. The Ph.D. degree requires the accumulation of at least 90 credit hours beyond the bachelor's degree (excluding all credit hours from an Engineer's degree).

Master's student may transfer a maximum of 9 credits from an outside institution approved by UF. Doctoral students may transfer up to 30 credit hours from a Master's degree in electrical and computer engineering taken at an outside institution approved by UF.

The Master of Engineering (M.E.) degree is awarded only to students with a B.S. in engineering, or to students who have completed appropriate articulation courses. The Master of Science (M.S.) degree is awarded to students with an undergraduate degree in any appropriate area of science or engineering.

All work counted for a Master's degree must be completed during the seven years immediately preceding the date on which the degree is to be awarded.

To graduate from any of the above-mentioned degree programs, a 3.00 is required in the overall (UF) and ECE-cumulative grade point averages.

An off-campus student who is a candidate for an electrical engineering degree must take at least half the course work from full-time University of Florida faculty members. Students can presently meet this requirement by attending lectures on the UF campus or using lectures distributed via distance learning.

No graduate credit is allowed for electrical and computer engineering courses below the 5000 level. Graduate students may take additional undergraduate courses, but credits earned in these courses are not counted toward the minimum degree requirements. A summary of the pertinent degree requirements is shown in the following table. For detailed requirements, see the appropriate sections that follow.

Requirements	ME (Thesis)	ME (Non-thesis)	MS (Thesis)	MS (Non-thesis)	Ph.D.
Total hours	30	30	30	30	90 ^a
ECE courses	18 ^{*h}	21 ^{*h}	18 ^{*h}	21 ^{*h}	24 ^{**h}
Minimum ECE credits	18 ^{*h}	21 ^{*h}	18 ^{*h}	21 ^{*h}	50%
Depth Requirement	9 ^{*hj}	9 ^{*hj}	9 ^{*hj}	9 ^{*hj}	N/A
Breadth Requirement	3 ^{*hi}	3 ^{*hi}	3 ^{*hi}	3 ^{*hi}	N/A
Minimum number of supervisory committee members	3	1	3	1	4 ^b
Qualifying Exam required	no	no	no	no	yes ^c
Final Exam	oral ^e	none	oral ^e	written ^d	oral ^f
Time limit for completing degree	7 years	7 years	7 years	7 years	5 years ^g

Footnotes:

- * Excludes: EEL 5905, 6905, 6910, 6932, 6940, 6971
- ** Excludes: EEL 5905, 6905, 6910, 6932, 6940, 6971, 7979, 7980
- a May include 30 hours from Master's program
- b Includes one member outside the ECE department
- c Written part within the first year of entry
- d Exam covers one 5000/6000 level course sequence
- e On thesis and course work
- f On dissertation
- g Five years from admission to candidacy
- h UF ECE courses only
- i Credit hours must be in a research division outside of depth research division
- j At least three credits must be at the 6000 level

2. Articulation Requirements

Students entering the graduate ECE program from a non-ECE background are welcome in the department.

All students must have completed course work in at least three of the eight topic areas cited in the Ph.D. qualifying exam, which currently include:

- Digital Logic
- Signals and Systems
- Electronic Circuits
- Solid-State Devices
- Electromagnetism and Energy Systems
- Microprocessor Applications
- Computer Organization and Architecture
- Data Structures and Operating Systems

These requirements may be satisfied, with a grade of B or higher, as follows:

- Previous undergraduate course work (e.g. physics course in electromagnetics, computer science courses in data structures and operating systems);
- Enrollment in and successful completion of appropriate UF undergraduate courses; or,
- Pass the Ph.D. written qualifying exam.

Additional courses may be required to fulfill necessary background material needed to successfully complete graduate-level course requirements. Many graduate-level ECE courses have implicit undergraduate course prerequisites. Students are expected to have mastered the undergraduate skills necessary to provide appropriate foundation for graduate courses they attempt.

All articulation requirements must be satisfied within the first 12 months of beginning graduate studies.

III. Master's Degree - Thesis Option

The Department of Electrical and Computer Engineering offers the thesis option for the Master of Engineering and Master of Science degrees. A student seeking a Master's degree with a thesis option is required to pass an oral final examination.

1. Course Requirements

For the thesis option of a Master's degree, students must complete at least 30 credit hours, which include a maximum of six credit hours of EEL 6971 (Research for Master's Thesis). Thesis students must be registered for three credit hours of thesis (EEL 6971) in the term of graduation (Fall and Spring, and two credits in summer). The course requirements include a minimum of 18 hours of Electrical and Computer Engineering courses, excluding EEL 5905, 6905, 6910, 6932, 6940, 6971. This course requirement can only be fulfilled by completing ECE course work at the University of Florida.

Students are required to complete a 12 credit hour depth/breadth requirement in order to receive a Master's degree in ECE. To complete this depth/breadth requirement, students must take at least 9 depth credits of ECE course work from one of the five research divisions housed in the ECE department (i.e., Computer Engineering, Devices, Electromagnetics and Energy Systems, Electronics, Signals & Systems). At least three of these nine depth credits must be at the 6000 level. In addition, students must complete at least three breadth credits of course work in the ECE department outside of their declared depth research division. Students can determine which ECE courses are housed in each research division by referring to the research division flow charts at the end of this manual. ECE courses used to complete this depth/breadth requirement will be counted toward the minimum 18 credits of ECE course work required for the Master's thesis degree.

Up to 18 hours of Special Topics (EEL 5934, 6935, and 7936) may be applied toward the degree. Up to six hours of unstructured credit hours total (EEL 5905, EEL 6905 or EGN 5949) may be applied toward the degree. Students can count a maximum of 3 credits of EGN 5949 toward their degree program.

Students holding a graduate research assistantship may register for EEL 6910 (Supervised Research) and those holding a graduate teaching assistantship may register for EEL 6940 (Supervised Teaching) with the supervisor's approval. The number of credits in EEL 6910 and 6940 is limited to five credit hours each and none of these credits can be counted toward degree requirements.

Students must receive a final grade of "C" or better to receive degree credit for a letter graded course. A course with a final grade of "C" and above cannot be repeated for credit. If a student receives a grade less than a "C" for a course, s/he may retake the course and an average of both grades will be used when compiling GPA graduation requirements. Courses in which students receive a grade of "C-" or lower will not be used to fulfill credit requirements but will adversely affect a students' GPA.

2. Appointment of Supervisory Committee

The supervisory committee is the group of faculty members that supervises and approves the student's graduate program. The committee's function is to guide the student through his/her thesis research and to administer the final examination.

The supervisory committee should be selected as soon as possible but no later than the end of the second semester. After the committee has been determined, the student should get a Supervisory Committee Form from the ECE Student Services Office (230 Larsen) and have the professors sign the form indicating their willingness to serve on the committee. The Graduate School may deny degrees to any persons who have failed to comply with this regulation at the proper time.

The committee for the Master's degree, thesis option, must consist of at least three graduate faculty members. The chairperson and at least one member must be a graduate faculty member in Electrical and Computer Engineering department. The chairperson is usually the student's academic advisor and should advise the student in the selection of the other committee members.

3. Submission of Master's Thesis

Students must submit their thesis electronically. Students should refer to the Graduate School Editorial Office for more information regarding their thesis submission.

(<http://gradschool.rgp.ufl.edu/editorial/introduction.html>)

Electronic submission requires a signed ETD Submission Approval Form, Final Exam form, and one electronic copy to the Student Services Office, 230 Larsen.

4. Final Examination Procedures

Up to six months prior to graduation, the supervisory committee will give the student an oral examination on the thesis, on major and minor subjects, and on matters pertaining to any specific field of study.

Each student is responsible for applying for his/her degree by the published deadlines for the semester of graduation. The degree application is available online via ISIS. Students are also required to meet with the Graduate Advisor in the Student Services Office at the beginning of the semester that they intend to graduate to assure that all degree requirements have been met. If a student fails to apply by the specified deadline, s/he will not receive the degree that semester.

It is imperative that copies of the student's thesis be given to the supervisory committee at least two weeks in advance of the final examination. Graduation may be delayed for those who do not adhere to this rule. When submitting your final copies of the thesis, be sure to deliver an electronic copy to the Student Services Office.

Students are also required to complete an Exit Survey during the semester they plan to graduate. Students can find more information about the Exit Survey in the Student Services Office.

5. Checklist for Thesis Option

	To Do	When
	If appropriate, transfer up to 9 credit hours from graduate courses taken previously to your UF master's program.	First semester
	Appoint supervisory committee. This committee must be appointed by the end of the second semester	Second semester
	Check with the Student Services Office to see if all graduation requirements, including appropriate course hour credit, will be satisfied.	Semester before graduation
	If you have any grades less than C (i.e. C-, D, I, or E grades), discuss your options for meeting graduation requirements.	
	Submit degree application online via ISIS. Complete graduation check in Student Services Office.	Semester of graduation
	Comply with Graduate School thesis and final examination deadline dates.	
	Be registered for at least the minimum number of thesis hours (3 hours in the fall and spring semester, 2 hours in the summer)	
	Schedule the Thesis Defense with the supervisory committee. Inform the Student Services Office of plans to take the examination, and reserve a conference room. The Student Services Office will send the announcement of exam and prepare the Final Exam Report.	
	At least one week in advance of the final examination, give the supervisory committee members a copy of the thesis.	
	On the day of the examination, report to the Student Services Office to pick up the necessary forms.	
	Have the Final Examination Report form and the original signature page of the thesis signed by the supervisory committee members. Return the Final Examination Report form to the Student Services Office.	
	Submit the final thesis, as required, to the department, the College Dean, and the Graduate School.	
	Complete the Exit Survey.	

IV. Master's Degree - Non-thesis Option

The Department of Electrical and Computer Engineering offers the non-thesis option for the Master of Engineering and Master of Science degrees. The non-thesis Master of Science student is required to pass a written final examination. No final exam is required for students pursuing the non-thesis Master of Engineering degree.

1. Course Requirements

For the non-thesis Master's degree option, students must complete 30 graduate level credit hours. At least 21 hours of ECE course work must be taken. This course requirement can only be fulfilled by completing ECE course work at the University of Florida. EEL 5905, 6905, 6910, 6932, 6940, and EGN 5949 are not counted for this requirement. No credit for EEL 6971 is allowed.

Students are required to complete a 12 credit hour depth/breadth requirement in order to receive a Master's degree in ECE. To complete this depth/breadth requirement, Students must take at least 9 depth credits of ECE course work from one of the five research divisions in the ECE department (i.e., Computer Engineering, Devices, Electromagnetics and Energy Systems, Electronics, Signals & Systems). At least three of these nine depth credits must be at the 6000 level. In addition, students must complete at least three breadth credits of course work in the ECE department outside of their declared depth research division. Students can determine which ECE courses are housed in each research division by referring to the research division flow charts at the end of this manual. ECE courses used to complete this depth/breadth requirement will be counted toward the minimum 21 credits of ECE course work required for the Master's non-thesis degree.

Master of Science non-thesis students must pass a final written examination (see section below). Master of Engineering non-thesis students do not have to complete a final written examination.

Up to 18 hours of Special Topics (EEL 5934, 6935, and 7936) may be applied toward the degree. Up to six hours of unstructured credit hours total (EEL 5905, EEL 6905 or EGN 5949) may be applied toward the degree. Students can count a maximum of 3 credits of EGN 5949 toward their degree program. No other S/U credit can be counted toward the degree.

All non-thesis students are required to have a one member supervisory committee. The ECE department chair serves as the default non-thesis committee member for all non-thesis students and is automatically appointed for all non-thesis students.

Students holding a graduate research assistantship may register for EEL 6910 (Supervised Research) and those holding a graduate teaching assistantship may register for EEL 6940 (Supervised Teaching) with the supervisor's approval. The number of credits in EEL 6910 and 6940 is limited to five credit hours each and none of these credits can be counted toward degree requirements.

Students must receive a final grade of "C" or better to receive degree credit for a letter graded course. A course with a final grade of "C" and above cannot be repeated for credit. If a student receives a grade less than a "C" for a course, s/he may retake the course and an average of both grades will be used when compiling GPA graduation requirements. Courses in which students receive a grade of "C-" or lower will not be used to fulfill credit requirements but will adversely affect a students' GPA.

2. Final Examination Procedures - *Master of Science only*

The M.S. non-thesis final examination is a comprehensive test of the student's knowledge in their declared depth research division and is administered in all 6000 level courses that have a 5000 level prerequisite course. Students can determine which ECE courses offer a MS non-thesis final examination by referring to the research division flow charts at the end of this manual. Students may complete the final MS non-thesis final exam in either EEL 6562 or EEL 6825 if they are in the process of completing both courses and in EEL 6487.

The MS non-thesis final exam is a separate assignment that is given in addition to required class assignments/exams. Students must take the MS non-thesis final exam during the semester that they are registered for the appropriate 6000 level ECE course. Professors will determine the format of the MS non-thesis final exam in their course. Some suggested formats include:

- Take home question(s) about the course and the student's understanding of the material.
- Extended project that includes material from the first course.
- Extended midterm exam which will include material from the first course of the sequence.
- Take home essay which covers research in breadth sequence.

In case of failure, the exam can be retaken the next time it is offered.

Students must register online in order to take the MS final exam. Online registration opens six weeks prior to the mid-point deadline of the semester.

Students will also be required to complete an Exit Survey during the semester in which they intend to graduate.

3. Checklist for Non-thesis Option

	To Do	When
	If appropriate, transfer up to 9 credit hours from graduate courses taken previously to your UF master's program.	First semester
	Take MS non-thesis final exam this semester. By the registration deadline, register for the MS non-thesis final exam online via the current graduate student web page of the departmental web site and indicate your selected area.	Second semester
	Check with the Student Services Office to see if all graduation requirements, including appropriate course hour credit, will be satisfied.	Semester before graduation
	If you have any grades less than C (i.e. C-, D, I, or E grades), discuss your options for meeting graduation requirements.	
	Submit degree application online via ISIS. Complete graduate check in Student Services Office.	Semester of graduation
	If you have not passed the Master's non-thesis final exam, take it this semester. By the registration deadline, register for the MS non-thesis final exam online via the current graduate student web page of the departmental web site and indicate your selected area.	
	Complete the Exit Survey.	

V. Doctor of Philosophy Degree

1. Course Requirements and Period of Concentrated Study

For the Ph.D. degree, at least 90 credit hours beyond the bachelor's degree are required. These hours include master's degree work taken at the University of Florida or, if appropriate, up to 30 hours of master's degree work in ECE earned at another approved university outside UF. The hours accumulated for the Ph.D. degree have the following restrictions:

- At least 24 hours of 5000, 6000, or 7000 level ECE courses are required. Students must receive a grade of "B" or better in these courses. These 24 hours must be approved by the student's faculty advisor. Students will need to work in conjunction with their faculty advisor to determine which courses will be most relevant to their research topic. EEL 5905, 6905, 6910, 6932, 6940, 6971, 7979, and 7980 are not considered course work for the purpose of this 24-hour requirement. ECE courses taken in a master's program at UF are automatically included. This course requirement can only be fulfilled by completing ECE course work at the University of Florida.
- All up to 18 hours of Special Topics (EEL 5934, 6935, and 7936) may be applied toward the degree. Up to six hours of unstructured credit hours total (EEL 5905, EEL 6905 or EGN 5949) may be applied toward the degree. Students can count a maximum of 3 credits of EGN 5949 toward their degree program.
- All EEL 7980 (Research for Doctoral Dissertation) credit hours are counted. Students cannot register for EEL 7980 hours until they have been officially admitted to candidacy (passed written exam and oral proposal). Students must be admitted to candidacy for a minimum of two semesters before graduation. Students can count the semester that they are admitted to candidacy if they complete their oral proposal by the midpoint deadline of a semester. The midpoint of the term is determined by the Graduate School and is published in its "Deadline Dates".
- Fifty percent of all hours accumulated have to be in ECE at the 5000, 6000 or 7000 level (including EEL 7979 & 7980).
- Only 30 hours from a Master's degree not awarded by the ECE department at UF may be counted toward the Ph.D. degree (see Transfer of Credit section of Administrative Procedures for more information).

Candidates for the doctoral degree must satisfy the minimum requirements for a period of concentrated study, beyond the first 30 semester hours counted toward the doctoral program. Students must complete 30 credits enrolled at the University of Florida campus or the Graduate Engineering and Research Center (REEF). Courses at the 1000 or 2000 level will not be counted toward the concentrated study requirement.

2. Appointment of Supervisory Committee

The supervisory committee is a group of faculty members who supervise and approve qualifications

for the Ph.D. degree. The committee should be appointed as soon as possible, but no later than the end of the second semester. The Graduate School may put a hold on the student's record if they do not meet this requirement. The committee consists of four or more graduate faculty members with at least two of the members having Graduate Faculty status in the ECE department. The committee chairperson must have Graduate Faculty status and be from the ECE department or have an appointment in the ECE department.

One member of the committee must be from a discipline outside of the department and must maintain graduate faculty status in their respective department.

After the committee has been determined, the student should obtain a Supervisory Committee Form from the Student Services Office (Larsen 230) and have the professors sign the form indicating that they are willing to serve on the committee.

3. Leave of Absence Policy

A doctoral student who will not be registered at UF for a period of more than one semester needs to request written permission from his/her faculty advisor for a leave of absence for a designated period of time. A copy of the written permission memo must be taken to the Student Services Office and placed in the student's file.

4. Official Minor

With the approval of the supervisory committee, a student may choose one official minor field (minimum 12 graduate credit hours). Official minor course work cannot be counted toward the 24 hour ECE course work requirement.

Minor work may be completed in any department, other than ECE, that is approved for master's or doctoral degree programs as listed in the *University of Florida Graduate Catalog* and supports a program that is related to the student's Ph.D. research area.

If an official minor is chosen, the supervisory committee must include a representative from the minor field.

If an official minor is chosen, a representative of the minor department, who may or may not be on the supervisory committee, shall designate at least one 6-hour graduate course sequence in the minor field for written qualifying examination. It is the student's responsibility to schedule the exam with the professor in the minor department. The student must pass this exam in order for the minor to be valid. The official minor exam must be completed before the student can be admitted to candidacy.

5. Written Portion of the Qualifying Exam

The Ph.D. written qualifying exam is a test reviewing fundamental material that students are expected to have covered before joining the doctoral program. The questions are taken from the following areas of ECE:

- Digital Logic
- Signals and Systems

- Electronic Circuits
- Solid State Devices
- Electromagnetism and Energy Systems
- Microprocessor Applications
- Computer Organization and Architecture
- Data Structures and Operating Systems

Each student selects three areas before the examination and receives two questions in each one of the selected areas. Answers must be given to four of the six questions, including at least one question from each of the three areas. The examination tests problem solving skills, fundamental understanding, reasoning ability, and written communication skills. The test will last for two hours. No materials are allowed during the examination. The department will provide scientific calculators for use during the exam.

The written qualifying exam is offered only once a year in January on a Saturday shortly after the start of Spring classes. Students must sign up for their selected areas in the Student Services Office by the end of November in the preceding year. Detailed study guides will be available in the fall semester.

Students must take the written qualifying exam during their first year in the doctoral program. Financial support may be contingent on taking the exam. Upon failure, the written qualifying exam can be retaken the next time it is offered. If more than two attempts are required, students may petition the Graduate Petitions Committee for permission to retake the exam. A successful petition must include a letter of support from the proposed Ph.D. advisor.

Students with a minor in another department have to arrange for a written qualifying exam in their minor to satisfy the Graduate School requirements. The exam must be administered by the student's minor supervisor.

6. Oral Portion of the Qualifying Exam

The oral part of the Ph.D. qualifying exam is usually taken one year after the satisfactory completion of the written portion of the qualifying exam. The oral part of the exam consists of:

- Presenting his/her written research proposal
- Answering questions asked by the supervisory committee and others present

The Student Services Office must be notified at least one week in advance of the oral qualifying examination so the Announcement of Examination form can be mailed and the Admission to Candidacy form prepared. This form should be taken to the qualifying exam by the student, signed by the supervisory committee and returned to the Student Services Office for processing.

If the student fails the oral portion of the qualifying exam, s/he may retake it only once and it must be retaken within two semesters.

If a student fails the oral portion of the qualifying examination for a second time, the Graduate School will be notified. A re-examination may be requested but it must be recommended by the student's supervisory committee and approved by the Graduate School. At least one semester of additional preparation is considered essential before re-examination.

Between the date of completion of the qualifying exam and the date of the degree, there must be a minimum of two semesters if the candidate is in full-time residence or a calendar year if the

candidate is in attendance on less than a full-time basis. The semester in which the qualifying examination is completed is counted provided that the exam is completed before the midpoint of the term. No more than five years may pass between the completion of the qualifying exam and the conferring of the degree.

The doctoral student becomes a doctoral candidate when the following requirements are satisfied:

- The student academic record is satisfactory.
- The 24 ECE credit hour requirement is complete.
- The Supervisory Committee certifies that the student has made satisfactory progress to be admitted to candidacy.
- The student has a dissertation topic approved by his/her supervisory committee.
- The student has passed both the written (including the official minor exam if applicable) and oral portions of the qualifying exam.
- The Admission to Candidacy form has the required formal approvals.

The ECE department requires that the student be admitted to candidacy as soon as the criteria listed above have been met but not later than three years after passing the written portion of the qualifying exam.

7. Final Examination and Submission of Dissertation

The Ph.D. final exam consists of an oral defense of the research results that are described in the doctoral dissertation. This exam is given within six months of graduation, after the first submission of the dissertation, and the completion of all other prescribed work for the degree.

Students must submit the dissertation electronically. Students should refer to the Graduate School Editorial Office for more information regarding their dissertation submission. The guidelines are also online (<http://gradschool.rgp.ufl.edu/editorial/introduction.html>).

Electronic submission requires a signed ETD Submission Approval Form, Final Exam Form, and one electronic copy to the Student Services Office.

The Student Services Office should be informed of the examination one week prior to the defense date in order to process the Final Exam Report form and send out notices.

Copies of the student's dissertation must be given to the supervisory committee members at least two weeks in advance of the final examination. Graduation may be delayed for those who do not adhere to this rule.

At the time of the defense, all committee members should sign the signature pages in the dissertation and sign the Final Exam Report form which is to be returned to the Student Services Office. Students will also submit the original copy of their dissertation to the Student Services Office.

Students are also required to complete an Exit Survey during the semester they plan to graduate. Students can find more information about the Exit Survey in the Student Services Office.

All work for the Ph.D. degree must be completed within five calendar years after the completion of the Ph.D. qualifying exam.

8. Checklist for Ph.D. Degree

	To Do	When
	Appoint supervisory committee. This committee must be appointed by the end of the second semester.	First Year Second Semester
	If appropriate, transfer non-UF master's course work (30 hours maximum) to doctoral degree.	
	Complete coursework requirement before taking the oral portion of the qualifying exam.	
	Take the written portion of the qualifying exam.	
	Arrange with the supervisory committee the details of your written research proposal that is to be defended in the oral exam.	Second Year
	If possible, take the oral portion of the qualifying exam within one year of the written portion. You MUST take the oral portion within three years after passing the written portion.	
	At least two weeks in advance of the oral exam, notify, in writing, the Student Services Office of plans to complete the qualifying exam.	
	Pass oral portion of the exam	
	Check with the Student Services Office to see if all graduation requirements, including appropriate course hour credit, will be satisfied.	Semester before graduation
	If you have any grades less than C (i.e. C-, D, I, or E grades), discuss your options from meeting graduation requirements.	
	Submit degree application online via ISIS. Complete graduation check in Student Services Office.	Semester of graduation
	Comply with Graduate School dissertation and final examination deadline dates	
	Be registered for at least the minimum number of dissertation hours (3 hours in the fall and spring semester, 2 hours in the summer)	
	Schedule the doctoral defense with the supervisory committee. Inform the Student Services Office of plans to take the examination one week prior to the exam and reserve a conference room. The Student Services Office will send the announcement of exam and prepare the Final Exam Report.	

Checklist for Ph.D. Degree – *Continued*

	To Do	When
	At least two weeks in advance of the final examination, give the supervisory committee members a copy of the dissertation	Semester of graduation
	On the day of the examination, report to the Student Services Office to pick up the necessary forms.	
	Have the Final Examination Report form and the original signature page of the dissertation signed by the supervisory committee members. Return the Final Examination Report form to the Student Services Office.	
	Submit the signed, original copy of the dissertation to the Editorial Office of the Graduate School. Submit an electronic copy to the Student Services Office.	
	Complete the Exit Survey.	

VI. Administrative Procedures

1. Graduate Bulletin Boards

At least once a week, check the ECE Graduate bulletin boards, located outside 230 Larsen Hall, for announcements, changes in course offerings or room schedules, notices of examinations, and for other matters of interest to ECE graduate students. Advising hours for the graduate academic advisor and Graduate Coordinator will also be posted on these bulletin boards.

2. Degree Audits

A student's degree audit is a condensed summary of their degree progress. Students can check their degree progress by viewing their degree audit online at <http://my.ufl.edu/>. Students are expected to periodically review their degree audit to monitor their academic progress. Degree audits are a guidance tool and should be used in conjunction with advisement resources available in the Student Services Office.

3. Gatorlink Email Accounts

All ECE students are required to check their Gatorlink email accounts regularly. The Student Services Office and the University of Florida uses the Gatorlink accounts to deliver important announcements and deadline information to students. Failure to adhere to changes in policy and/or critical deadlines will result in delayed degree progress.

4. Graduate Registration

Students can register for classes online at <http://my.ufl.edu/>. The Student Services Office is also available for help with registration and for registration to departmentally controlled courses.

Graduate students on appointment (TA, RA, GA) must register for the appropriate course load as indicated in the table below. Audited courses do not count as part of the hourly requirements for full time students or those on assistantships.

Appointment	Minimum Credit	Maximum Credit
Fellows and Trainees	12	18
1/4 Time Assistants	9	15
1/3 Time Assistants	9	15
1/2 Time Assistants	9	15
3/4 Time Assistants	6	9
Full-Time Assistants	3	3

Graduate students may not, in general, take any course under the S/U option except for certain graduate courses that have only S/U grading (as specified in the Graduate Catalog). Master's thesis and PhD students who complete all graduate degree requirements during a given semester, but after the deadlines specified by the Graduate School, may receive their degree in the following semester without registering as clear prior students. Graduate School will determine a student's clear prior eligibility. Students whose degree requirements are not completed before the first day of

classes of the following semester and all non-thesis Master's students must register for a minimum of three credit hours (two credits in the summer term) which will apply to the degree. ***The Graduate School will not accept petitions to this policy.*** The minimum registration is only applicable if the student is not on appointment.

5. Add/Drop Policy

Graduate students are allowed a limited number of schedule adjustments after the midpoint deadline of the semester*. Students are permitted one schedule adjustment after the midpoint deadline per degree program. A schedule adjustment is defined as any of the following: adding a course, dropping a course, and/or switching course work hours for another course (research hours, independent study, etc.). Student's requesting additional adjustments must petition the Graduate Coordinator for approval. A successful petition would require a letter of support from the student's faculty advisor.

***Students will be held fee liable for ANY course adjustments made after the stated university add/drop deadline.**

6. GPA and Probation Policies

In compliance with Graduate School rules, graduate students must maintain a GPA of 3.00 or higher in order to be in good standing. Students cannot graduate if their GPA is below 3.00.

Please note that the term "GPA" includes three different numbers, all of which need to satisfy the requirement of 3.00 or higher.

- The grade point average of ***all courses*** (3000 level and above) taken while classified as a graduate student;
- The grade point average of ***all ECE graduate level courses*** taken while classified as a graduate student;
- The grade point average of all graduate level courses that are part of a minor.

An academic hold will be placed on the records of all students whose GPA is below 3.00, thus placing the student on academic probation. These students will be able to register for courses only through the Student Services Office. This will enable our office to provide advice and guidance on an individualized basis.

Students on academic probation are not entitled to receive financial assistance in the form of Teaching Assistantships, Research Assistantships, or Fellowships.

Students with a GPA below 3.00 must show progress each semester towards improving their GPA, even if it takes more than one semester to reach a GPA of 3.00 or higher.

Students who do not make sufficient academic progress as determined by the Graduate Coordinator will be dismissed from the program.

7. Transfer of Credits

Up to 9 credit hours of graduate level engineering and science courses passed with a grade of "B" or better may be transferred from an outside institution. Up to 15 credits of graduate level non-degree

seeking UF/EDGE course work passed with a “B” or better may be transferred into a student’s graduate degree program. No more than 15 credits may be transferred into the student’s Master’s degree program. No more than 30 credits may be transferred into the student’s PhD degree program. Students may also petition to transfer graduate level courses which were taken while classified as an undergraduate, postbaccalaureate, or non-degree seeking student, if proof is provided indicating that courses were not used to satisfy degree requirements for another degree. Credits obtained in non-degree programs, e.g. continuing education, may not be transferred. Credits transferred will be applied toward meeting the degree requirements, but the grades earned will not be computed in the student’s grade point average unless the course work was completed at UF.

Application for transfer of credit earned after admission to a UF graduate program must be filed with the Graduate School as soon as possible but before the last day of classes preceding the term in which the degree is to be conferred. The student must provide a complete description of the graduate course in consideration for transfer and a transcript indicating the grade earned. The approval of the Graduate Coordinator and the Dean of the Graduate School are required for the acceptance of transfer credits.

8. Internship Policy

Effective Spring 2010, ECE students can count up to three credits of EGN 5949 (Internship Work) toward their degree program.

In order to participate in the ECE Graduate Internship Program, students must have completed at least 18 UF ECE graduate level credits. Students must also have a minimum departmental and cumulative grade point average of 3.0. International students will also need to contact the International Center to verify their CPT eligibility. Internships are voluntary and are meant to compliment a student’s degree program. Internships that impede a student’s timely progress toward their degree will not be approved. Students who choose to complete an internship must be cognizant of the appropriate academic deadlines. Internships CANNOT conflict with the start and end dates of the academic semester.

Students who hold appointments at UF must be cognizant of the start and end dates of their appointments while making internship plans. Students are not permitted to be on appointment and be on internship at the same time. Students on appointment are responsible for knowing the start and end dates of their appointment when negotiating the timeframe of their internship. **Students who arrange internships that conflict with their UF appointment start and/or end dates will NOT be appointed for that semester.**

To be classified as an internship and to receive up to three elective credits (EGN 5949), the job duties of the internship must consist of engineering design. Positions not acceptable for graduate internship credit include undergraduate level work, technician, data entry, clerical work, part-time work, etc. Students must also complete a technical report in order to receive credit for their internship.

Students can count a maximum of 3 credits of EGN 5949 toward their degree program. Internship credits will count toward the independent study total of a student’s degree program (i.e., Master’s students can only count a maximum of 6 credits of EEL 5905, EEL 6905, and/or EGN 5949 toward their degree program).

Each student is required to generate a technical report (2000 word minimum excluding graphs, equations, circuits, and/or computer code) to receive credit for their internship. The report must meet IEEE publication guidelines and include the following: title, author’s name, abstract, introduction of the tasks carried out, methodology used, results, discussion, acknowledgements, and references.

Confidential material should not be included, but students are expected to include technical details and assessments, equations, graphs, circuits, etc.

More information about the ECE Graduate Internship Program can be found in the Student Services Office.

9. Financial Aid

Applications for teaching assistantships, research assistantships and fellowships are available from the Department of Electrical and Computer Engineering. Fellowships are highly competitive and generally require completed applications by January each year. Recipients of teaching assistantships are selected by the Associate Chairman of the ECE department. Research assistantships are awarded by individual faculty members with funding from governmental or industrial sources and are generally awarded only to those students who have been in residence at least one semester.

The minimum stipend for students on appointment in the ECE department is \$18,000 for a 12 month appointment. Minimum stipends for other departments and assigned duties for teaching assistants are determined by the Graduate School and are in accordance with the assistantship appointment. Duties include grading, staff meetings, class preparation, student consultation, required lecture attendance, and research not directly related to the student's thesis or dissertation. Students will also have assigned classroom or laboratory teaching responsibilities. International students who wish to be eligible for graduate assistantships must pass the SPEAK (TSE) or TOEFL iBT test. The passing score for the SPEAK test is 55. Students who score a 45 or 50 must take EAP 5836, Academic Spoken English, but are still allowed to hold a graduate assistantship. A passing score for the TOEFL iBT test is a 28. Students who score in the 23-27 range must enroll in EAP 5836 during your first semester of teaching. Students who score less than 23 on the TOEFL iBT will be required to take the SPEAK test to be considered for a TA position. Effective Fall 2009, EAP 5836 will NOT be covered by tuition waivers.

10. Tuition Waivers

Tuition waivers are awarded to graduate students who have been awarded an assistantship from 1/4 time - 1/2 time. Fee waivers are contingent on the availability of funds. Due to the limit of available funds, no fee waivers are available without assistantship appointments. The waivers are processed under strict guidelines provided by the Graduate School.

11. Assistantships While on Internship

Due to intellectual property rights, it is the policy of the ECE department that students on an assistantship cannot keep their assistantship while on a internship. It is expected that a student with an assistantship fulfill the terms of that assistantship.

Students who hold appointments at UF must be cognizant of the start and end dates of their appointments while making internship plans. Students are not permitted to be on appointment and be on internship at the same time. Students on appointment are responsible for knowing the start and end dates of their appointment when negotiating the timeframe of their internship. Students who arrange internships that conflict with their UF appointment start and/or end dates will NOT be appointed for that semester. The assistantship will be terminated and the tuition waiver cancelled for students who leave for a paid internship after the semester has begun. The student will be liable for all fees covered by the tuition waiver at the appropriate rate.

Students returning from a paid internship after the semester has started will not be reappointed to the assistantship until the beginning of the following semester.

12. Readmission Procedures

Students who have left the program prior to graduating and wish to be readmitted, require the following:

- A minimum GPA of 3.00 for readmission into the Master's program and a minimum GPA of 3.5 for readmission to the Ph.D. program.
- GRE scores that satisfy the admission requirements of the ECE program in effect at the time of readmission.
- Three letters of recommendation from faculty members in the ECE department.

Readmission is not guaranteed, irrespective of the circumstances that necessitate it.

|

VII. Graduate Course Descriptions

Websites for the graduate courses are at www.ece.ufl.edu/academics/classwebsites.html provided the professor requested the addition by emailing the departmental webmaster.

EEE 5320 - Bipolar Analog IC Design (3 credits)

Prereq: EEL 3304C

Amplifier stages, active loads, output stages, op-amps, feedback, frequency response, compensation.

EEE 5322 - VLSI Circuits and Technology (3 credits)

Prereq: EEL 3396 and EEL 3304.

Introduction to VLSI circuit technology and manufacturing fabrication, device models, layout, parasitics, and simple gate circuits.

EEE 5336L - Solid State Technology Laboratory (1 credit)

Solid-state device fabrication. Safety issues.

EEE 5317C - Introduction to Power Electronics (3 credits)

Prereq: EEL 3304C, 3396. Coreq: EEL 4657.

Components and circuits for power applications. Switched-mode power supplies.

EEE 5400- Future of Microelectronics Technology (3 credits)

Prereq: EEL 3396 or equivalent.

Survey of state-of-the-art microelectronics technology and prospects for future technologies.

Nanoscale MOSFETs, strained Si, high-K gate dielectrics, carbon nanotubes, molecular electronics, and single-electron devices.

EEE 5405- Microelectronic Fabrication Technologies (3 credits)

Prereq: EEL 3396.

Principles of microelectronic device fabrication. Emphasis on the fundamentals of micro-fabrication processing and microelectronic device process flows. Computerized process simulation.

EEE 5426- Introduction to Nanodevices (3 credits)

Prereq: 3396.

Physical principals of modern solid-state devices and their applications; quantum mechanics; fundamentals of nanoelectronics.

EEE 6321 - MOS Analog IC Design (3 credits)

Prereq: EEE 5320.

Design of analog circuits in CMOS IC technologies. MOS switches, MOS op-amps, circuit simulation using SPICE.

EEE 6323 - Advanced VLSI Design (3 credits)

Prereq: EEE 5322.

Advanced very large scale integrated circuit design, testability, and performance evaluation. Use of industrial VLSI software. Building an advanced CMOS VLSI circuit.

EEE 6325 - Computer Simulation of Integrated Circuits and Devices (3 credits)

Prereq: Graduate standing.

Basic methods of numerical simulation of semiconductor devices and electronic circuits with reference to PISCES and SPICE. PDE discretization; numerical integration, Newton/iterative linearization, linearized system solution.

EEE 6328C - Microwave IC Design (3 credits)

Fundamentals of microwave integrated circuit design. Use of computer software to design simple microwave circuits. Microwave circuit testing.

EEE 6374 - RF Circuits and Systems (3 credits)

Prereq: EEE 5322, 4306 or equivalent.

Requirements for RF integrated circuits. Design and implementation. Interdependence of RF circuit performance with devices, parasitics, packages, and process technology.

EEE 6382 - Semiconductor Physical Electronics (3 credits)

Prereq: EEE 5426.

Crystal structure and symmetry; carrier statistics; lattice dynamics; energy band theory; equilibrium properties of semiconductors; recombination-generation and trapping processes; electronic transport phenomena; scattering mechanisms; optical properties.

EEE 6390 - VLSI Device Design (3 credits)

Prereq: EEE 5400 or EEE 5426.

Criteria and tradeoffs involved in design of high-performance semiconductor devices in scales (VLSI) Si-based integrated-circuit technologies.

EEE 6397 - Semiconductor Device Theory (3 credits)

Prereq: EEL 4351/ EEE 5426.

Semiconductor device physics, equilibrium and non-equilibrium process; pn junctions; BJT operation, change-control modeling, high-current and heavy doping effects.

EEE 6402- Nonclassical Si-Based Nanoscale CMOS Devices (3 credits)

Prereq: EEE 6390 or EEE 6397.

Physics underlying novel devices for extreme CMOS scaling. Unique effects in fully depleted SOI MOSFETs, multi-gate MOSFETs, FinFETs. Simulation-based project using a physics/process-based compact model for double-gate FETs.

EEE 6428- Computational Nanoelectronics (3 credits)

Prereq: EEL 4351/ EEE 5426 or EEL 4329/EEE 5400

Using nanotechnology simulation tools to study nanoscale devices; band structure, transport; molecular transistors, nanowires, nanotransistors, and quantum dots.

EEE 6431- Carbon Nanotubes (3 credits)

Prereq: EEE 5426.

Basic semiconductor and solid-state physics of carbon nanotubes, nanotube geometrical and electronic structure, and current nanotube research.

EEE 6460- Advanced Microsystem Technology (3 credits)

Prereq: EEL 5225.

Advanced micro-fabrication technologies, micro-system design, interface circuits, and MEMS packaging. CMOS, Optical, and RF MEMS.

EEE 6465- Design of MEMS Transducers (3 credits)

Prereq: EEL 5225.

Design of MEMS transducer systems with physical, technological, and economic constraints.

EEL 5182 - State Variable Methods in Linear Systems (3 credits)

Prereq: EEL 4657

Linear algebra and state variable methods for design and analysis of discrete and continuous linear systems.

EEL 5225 - Principles of MEMS (Micro-Electro-Mechanical Transducers) (3 credits).

Prereq: EEL 3396 or permission of instructor.

Introduction to principles of micro-electro-mechanical devices and systems.

EEL 5400- Airborne Sensors and Instrumentation (3 credits)

Remote sensing problems are formulated in terms of information extraction to decide what sensors and algorithms are needed for a given application.

EEL 5401- Airborne Laser Scanning: Data Processing & Analysis (3 credits)

Students learn how to acquire, process, and analyze laser ranging data and to utilize it for several earth science applications.

EEL 5441 - Fundamentals of Photonics (3 credits)

Prereq: EEL 3396 and 3472.

Review of electromagnetic fields and waves, energy bands in semiconductors, p-n junctions and optical properties of semiconductors. Fundamentals of optical modulators and switches, laser theory, laser characteristics, photodetectors, optical waveguides, and photonic applications.

EEL 5451L - Photonics Lab (2 credits)

Prereq: EEL 4440 or 4445 or 5441.

Experiments in wave optics, acousto-optics, lasers, fiber optics, planar wave guides, and coherent optics.

EEL 5490 - Lightning (3 credits)

Prereq: EEL 3472.

Introduction to lightning discharge processes. Electromagnetics relevant to lightning measurements. Applications for determining lightning charge, current, location, and characteristics. Lightning protection.

EEL 5544 - Noise in Linear Systems (3 credits)

Passage of electrical noise and signals through linear systems. Statistical representation of random signals, electrical noise, and spectra.

EEL 5525 - Foundations of Digital Signal Processing (3 credits)

Analysis and design of digital filters for discrete signal processing; spectral analysis; fast Fourier transform.

EEL 5547 - Introduction to Radar (3 credits)

Prereq: EEL 4516 or 5544.

Basic principles of cw and pulsed radar; angle, range, and doppler tracking; accuracy and resolution; signal design.

EEL 5666C - Intelligent Machines Design (4 credits)

Prereq: EEL 4744C.

Design simulation, fabrication, assembly, and testing of intelligent robotic machines.

EEL 5718 - Computer Communications (3 credits)

Prereq: EEL 4514.

Design of data communication networks: modems, terminals, error control, multiplexing, message switching, and data concentration.

EEL 5764 - Computer Architecture (3 credits)

Prereq: EEL 4713C, 4744C, or equivalents.

Fundamentals in design and quantitative analysis of modern computer architecture and systems, including instruction set architecture, basic and advanced pipelining, superscalar and VLIW instruction-level parallelism, memory hierarchy, storage, and interconnects.

EEL 5840 - Elements of Machine Intelligence (3 credits)

Engineering and hardware concepts pertaining to design of intelligent computer systems.

EEL 5905 - Individual Work (1-4 credits per section number); (max: 6 credits count toward graduation)

Prereq: consent of adviser.

Selected problems or projects.

EEL 5934 - Special Topics in Electrical and Computer Engineering (1-3 credits per section number; max: 18 credits count toward graduation)

EEL 6264 - Advanced Electric Energy Systems (3 credits)

Prereq: consent of instructor. Energy systems planning and operation with emphasis on advanced analysis methodologies and computer simulation.

EEL 6265 - Advanced Electric Energy Systems II (3 credits)

Prereq: EEL 6264.

Continuation of EEL 6264 with additional emphasis given to the new electric energy technologies.

EEL 6447 - Laser Electronics (3 credits)

Prereq: EEL 3473 and EEL 5441 or equivalent.

Study of lasers from basic principles to operational characteristics.

EEL 6486 - Electromagnetic Field Theory and Applications I (3 credits)

Prereq: undergraduate course in fields and waves. Advanced electrostatics, magnetostatics, time-varying electromagnetic fields, wave propagation, waveguides.

EEL 6487 - Electromagnetic Field Theory and Applications II (3 credits)

Prereq: EEL 6486.

Electromagnetic radiation, antennas, wave propagation in an isotropic media.

EEL 6502 - Adaptive Signal Processing (3 credits)

Prereq: EEL 5544, EEL 5525.

Theory of adaptation with stationary signals; performance measures. LMS, RLS algorithms. Implementation issues and applications.

EEL 6503 - Spread Spectrum (3 credits)

Prereq: EEL 5544 and EEL 6535.

Techniques and applications; spreading sequence design; code division multiple access; multi-user detection.

EEL 6507 - Queuing Theory and Data Communications (3 credits)

Prereq: EEL 5544.

Introduction to basic Queuing models; performance analysis of multiple access protocols; error control strategies.

EEL 6509 - Wireless Communications (3 credits)

Prereq: EEL 5544.

Introduction. Satellite and cellular systems, propagation, modulation techniques, multiple access techniques, channel coding, speech and video coding, and wireless computer networks.

EEL 6527 - Digital Filtering (3 credits)

Prereq: EEL 5525.

Introduction to number transforms, complexity of algorithms, and finite fields. Development of transforms and digital filters using algebraic operators and finite fields plus the technological consideration of DSP systems and system integration.

EEL 6532 – Information Theory (3 credits)

Prereq: EEL 5544.

Basic introduction to information theory. Applications of information theory to communications and other related areas.

EEL 6533 - Statistical Decision Theory (3 credits)

Prereq: EEL 5544.

Hypothesis testing of signals in the presence of noise by Bayes, Neyman-Pearson, minimax criteria; estimation of signal parameters.

EEL 6535 - Digital Communications (3 credits)

Prereq: EEL 5544.

Optimum receiver principles; analysis of digital and analog communication systems in the presence of noise; modeling of communication channels.

EEL 6537 - Spectral Estimation (3 credits)

Prereq: EEL 5544 and EEL 5525.

Measurement and analysis of signals and noise. Digital filtering and spectral analysis; fast Fourier transform.

EEL 6550 - Error Correction Coding (3 credits)

Prereq: EEL 5544 or equivalent; Coreq: EEL 5544 or EEL 4516.

Introduction to abstract algebra, block coding and decoding, convolutional coding and decoding, trellis coded modulation, run-length-limited codes.

EEL 6562 - Image Processing and Computer Vision (3 credits)

Pictorial data representation; feature encoding; spatial filtering; image enhancement; image segmentation; cluster seeking; two-dimensional z-transforms; scene analysis; picture description language; object recognition; pictorial database; interactive graphics; picture understanding machine.

EEL 6586 - Automatic Speech Processing (3 credits)

Prereq: EEL 5525.

Various models of speech production and perception. Operation of speech synthesizers. Discussion of speech recognition. Mathematical models of speech signals.

EEL 6591 - Wireless Networks (3 credits)

Prereq: EEL 5718 and knowledge of probability and statistics.

Design and analysis of wireless networks including channel characteristics, physical layer, cellular concepts, multiple access control protocols, FEC and ARQ protocols, resource allocation, and wireless standards.

EEL 6614 - Modern Control Theory I (3 credits)

Prereq: EEL 5182.

Optimization of systems using the calculus of variations, dynamic programming, and the maximum principle. Extensive study of the linear plant with a quadratic performance index. Observers and dynamic compensators.

EEL 6617 - Linear Multivariable Control (3 credits)

Prereq: EEL 5182, MAS 4105.

Transfer matrix theory of systems, emphasis on feedback, internal stability, model matching and the assignment of invariant factors.

EEL 6706 - Fault Tolerant Computer Architecture (3 credits)

Prereq: EEL 5764 or CDA 5155.

Design and quantitative analysis of fault tolerant architectures and dependable systems including fundamental issues, redundancy techniques, evaluation methods, design methodology, and applications.

EEL 6763 - Parallel Computer Architecture (3 credits)

Prereq: EEL 5764.

Advanced architecture emphasizing design and quantitative analysis of parallel architecture and systems, including theory, hardware technologies, parallel and scalable architectures, and software constructs.

EEL 6769 - Hardware-Software Interactions: Nonnumeric Processing (3 credits)

Prereq: EEL 6767, COP 5725 or consent of instructor.

Information representations; content and context search methods; associative memories, retrieval language mapping; parallel processing; hardware and software garbage collections.

EEL 6814 - Neural Networks for Signal Processing (3 credits)

Prereq: EEL 5525.

Optimal filters in vector spaces. Linear machines and discriminant functions. Gradient descent learning in the additive neural model. Performance measures of multilayer perceptions and Hopfield networks. Dynamic neural networks and the issues of short term memory. Unsupervised learning networks.

EEL 6825 - Pattern Recognition and Intelligent Systems (3 credits)

Decision functions; optimum decision criteria; training algorithms; unsupervised learning; feature extraction, data reduction; potential functions; syntactic pattern description; recognition grammars; machine intelligence.

EEL 6841 - Machine Intelligence and Synthesis (3 credits)

Prereq: EEL 5840.

Theory of machine intelligence applied to general problems of engineering intelligent computer systems and architectures. Applications emphasized.

EEL 6892 - Virtual Computers (3 credits)

Prereq: EEL 5764 or COP 5615 or equivalents.

Techniques for virtualization of networked computer systems. Virtual machines (classic Vms, application binary interface Vms, para-virtualization) virtual distributed file systems (file system proxies, call-forwarding) virtual networks (tunneling, virtual private networks).

EEL 6905 - Individual Work (1-4 credits*; max: 6 credits.**)

Prereq: consent of advisor.

Selected problems or projects.

EEL 6910 - Supervised Research (1-5 credits***; max: 3 credits.**) S/U grading.

EEL 6935 - Special Topics in Electrical and Computer Engineering (1-4 credits*; **)

Topics vary.

EEL 6940 - Supervised Teaching (1-5 credits***; max: 3 credits.**) S/U grading.

EEL 6971 - Research for Master's Thesis(1-15 credits*, max: 6 credits**) S/U grading.

EEL 6972 - Research for Engineer's Thesis (1-15 credits*) S/U grading.

EEL 7979 - Advanced Research (1-12 credits*)

Research for doctoral students before admission to candidacy. Designed for students with a master's degree in the field of study or for students who have been accepted for a doctoral program. Not open to students who have been admitted to candidacy. S/U grading.

EEL 7980 - Research for Doctoral Dissertation (1-15 credits*) S/U grading.

EEN 5949: Practicum/Internship/Cooperative Work Experience (1-6; max: 2 credits.**)

Prereq: graduate student. Practical cooperative engineering work under approved industrial and faculty supervision. S/U.

* per section number.

** count for graduation.

*** no more than five hours may be taken.

**** maximum of 18 credit hours of EEL 5934, EEL 6935, EEL 7936.

VIII. Graduate Research Division Flow Charts

1. Computer Engineering

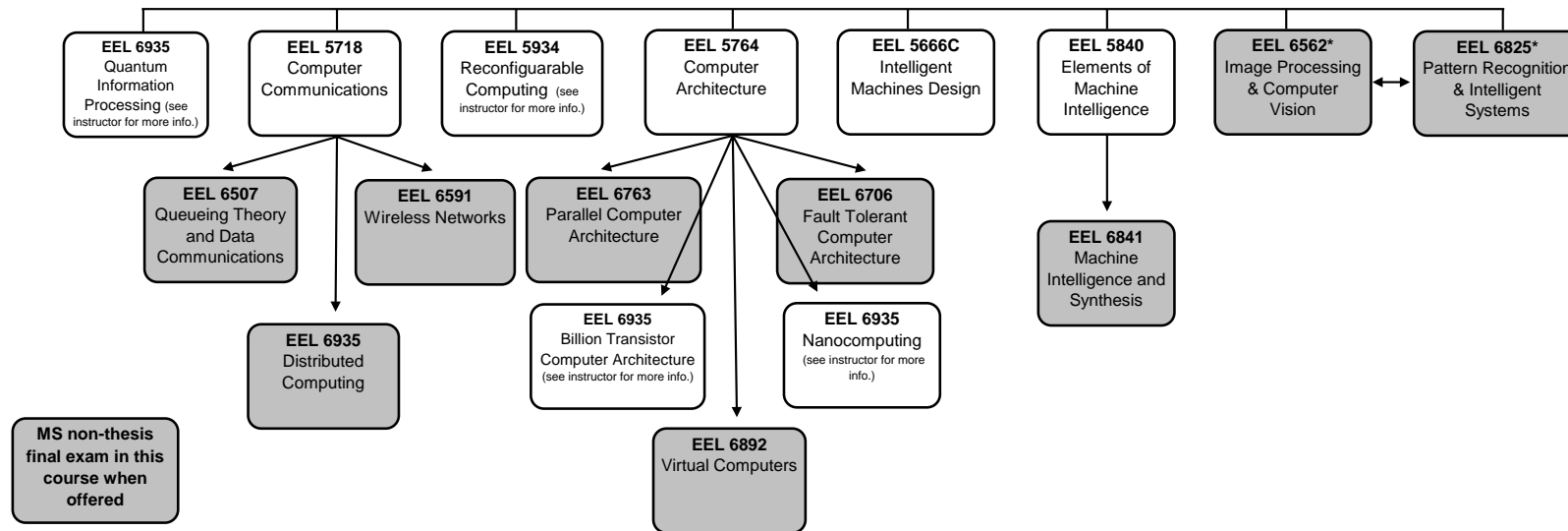

Suggested Plans of Study

Computer Systems

(EEL 5718)- Computer Communications
 (EEL 5764)- Computer Architecture
 EEL 6507 Queueing Theory
 EEL 6706- Fault Tolerant Computer Architecture
 EEL 6763- Parallel Computer Architecture
 EEL 6892- Virtual Computers
 EEL 6935- Autonomic Computing
 EEL 6935- Distributed Computing

Distributed & Parallel Computing

(EEL 5718)- Computer Communications
 (EEL 5764)- Computer Architecture
 EEL 6507 Queueing Theory
 EEL 6706- Fault Tolerant Computer Architecture
 EEL 6763- Parallel Computer Architecture
 EEL 6892- Virtual Computers
 EEL 6935- Autonomic Computing
 EEL 6935- Distributed Computing
 COP 5255- Concurrent Programming

Computer Architecture

(EEL 5718)- Computer Communications
 (EEL 5764)- Computer Architecture
 EEL 6706- Fault Tolerant Computer Arch.
 EEL 6763- Parallel Computer Architecture
 EEL 6892- Virtual Computers
 EEL 6935- Billion Transistor Architectures
 CDA 6156- Advanced Computer Architecture

Robotics

(EEL 5401)- Airborne Laser Scanning
 (EEL 5840)- Elements of Machine Intelligence
 (EEL 5666C)- Intelligent Machines Design Lab
 EEL 6562- Image Processing & Computer Vision
 EEL 6825- Pattern Recognition
 CAP 5635- Artificial Intelligence Concepts
 EML 6281- Robot Geometry I
 EML 6282- Robot Geometry 2

*Must complete both courses to take MS non-thesis final exam
 (Recommended Foundation Courses)

2. Devices

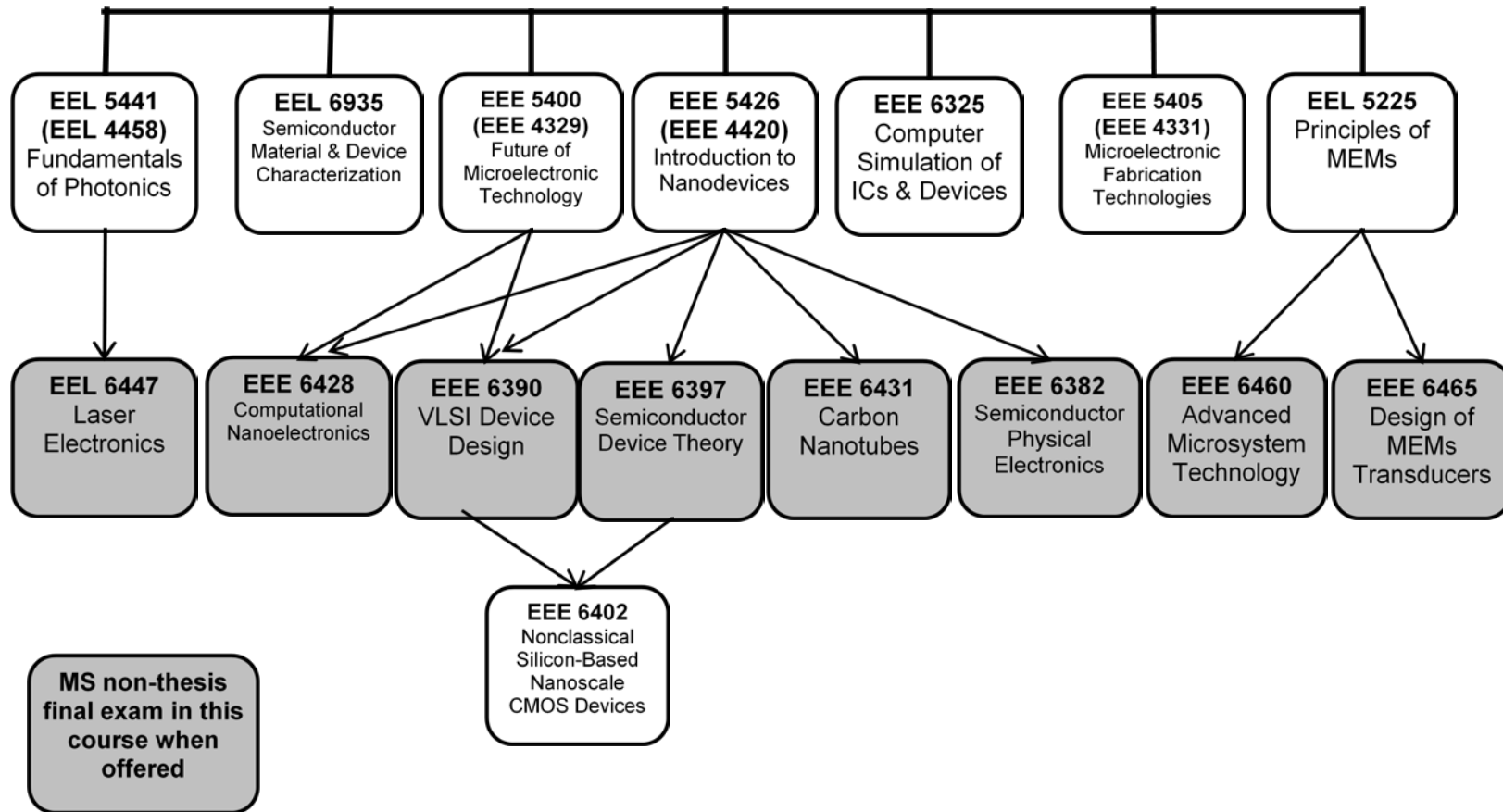

3. Electromagnetics & Energy Systems

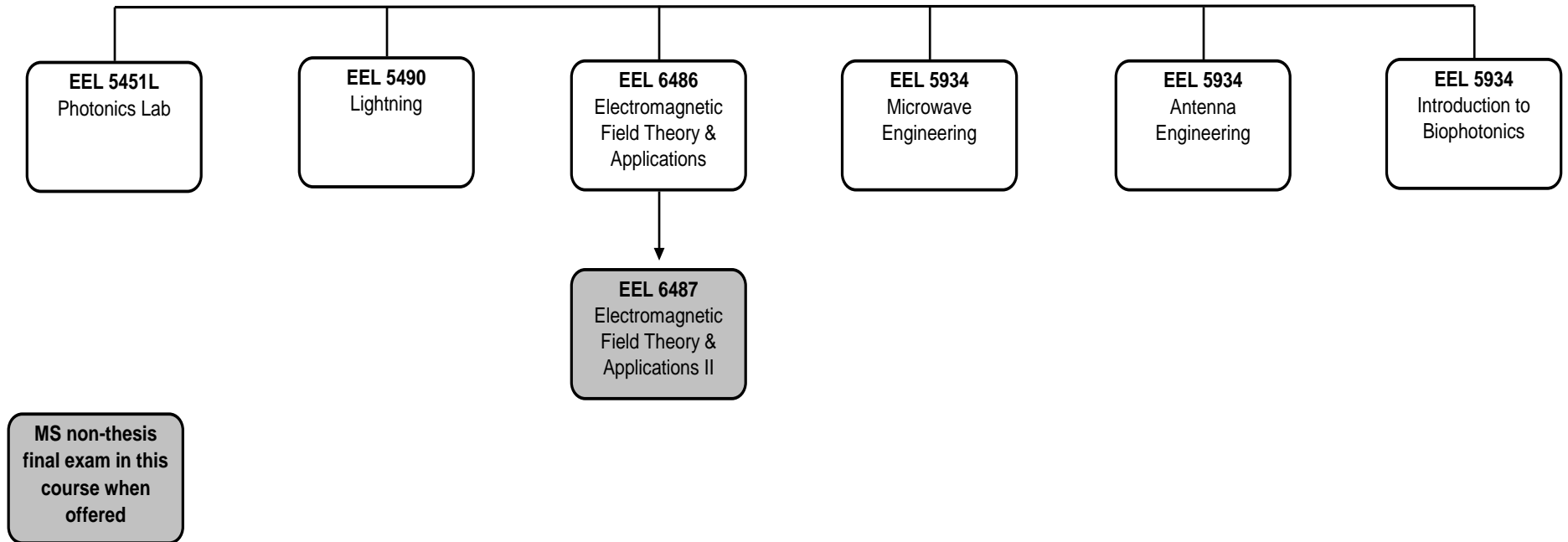

4. Electronics

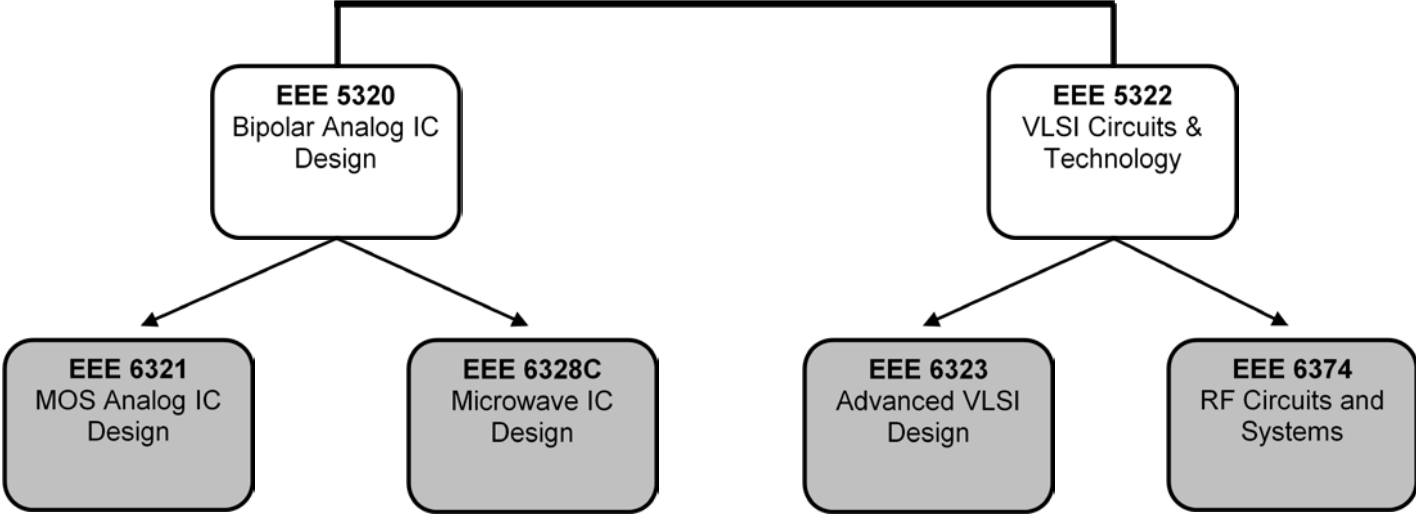

**MS non-thesis
final exam in this
course when
offered**

5. Signals & Systems

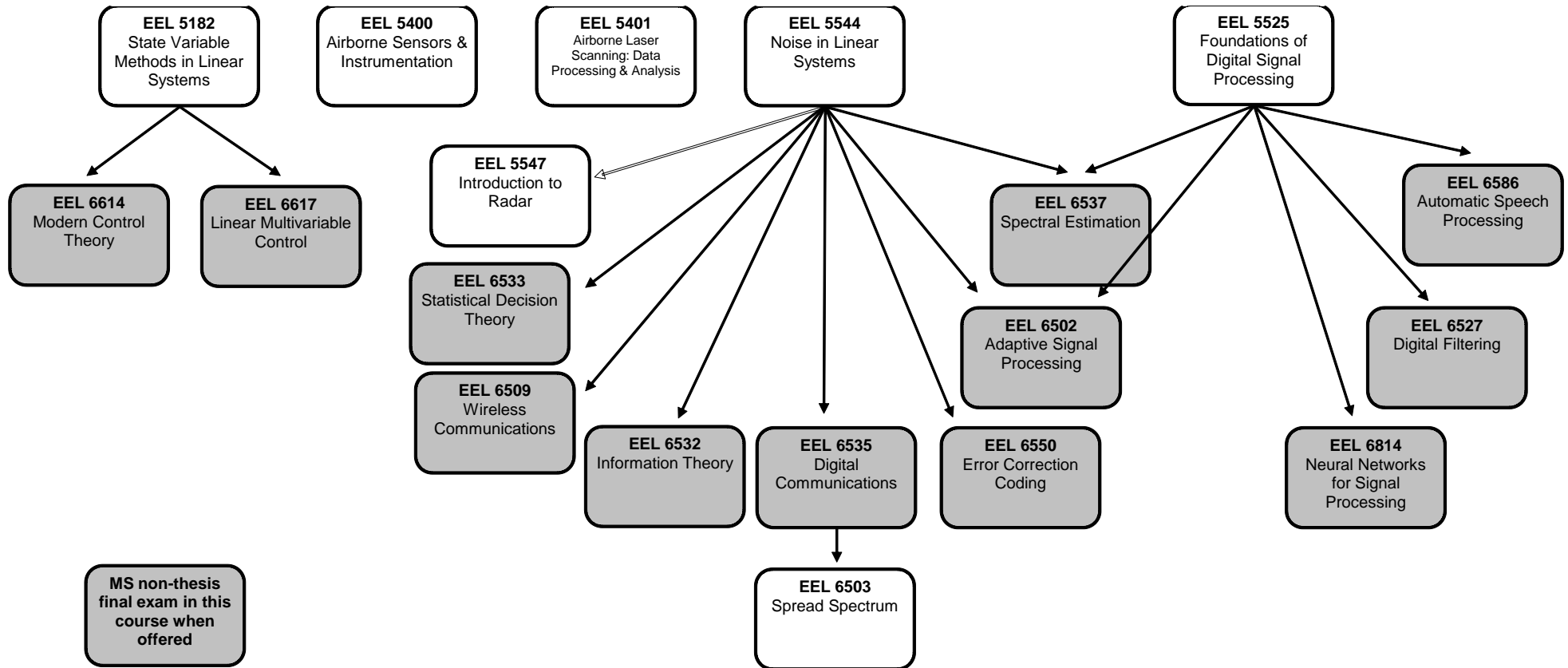

Suggested Plans of Study

Fall Semester	Spring Semester
EEL 5182	Choose One: EEL 6614 or EEL 6617
EEL 5544	EEL 6535
EEL 5525	Choose One: EEL 6502, EEL 6537, EEL 6586, EEL 6527